

Lighting know-how

DALI

Manual



TRIDONIC

Table of contents

Introduction: DALI standard 3

History	3
Features of DALI	4
Technical features of a DALI circuit	5
Scene and group concept	5
Positioning of DALI	6

Overview of DALI controllers and DALI control gear 7

DALI controllers of comfortDIM product series	7
DALI interface modules	12
DALI devices	13
Miscellaneous	16

comfortDIM product series in detail 17

DALI power supply	17
DALI XC	18
DALI TOUCHPANEL 02	33
DALI x/e-touchPANEL 02	38
DALI MSensoren	43
DALI USB	46

Designing a DALI application 48

Conventional wiring or DALI	48
Design considerations	48
Sample applications	53

Start-up 60

Before you get started	60
Sample set-up for a conference room	61

Maintenance and troubleshooting 72

Failure of a DALI Driver	72
Exceeding the maximum cable length or short-circuits in the DALI circuit	72
Double addressing problem at set-up	75

Annex 76

Technical features of a DALI circuit	76
Important DALI parameters and DALI commands	77
Current draw of the comfortDIM products in the DALI circuit	79
DALI MSensor broadcast commands and luminaire group commands	80
Reference list	82

Introduction: DALI standard

1.1. History

The agreement by the lighting industry to adopt a common protocol for digital addressable control of luminaires has opened up a virtually unlimited number of options for regulating artificial lighting in all applications. This common protocol is the DALI protocol (Digital Addressable Lighting Interface), which has now been internationally standardised through the IEC.

With the right choice of individual DALI components an extremely wide range of requirements can be met, from operating the lighting system from a simple light switch to lighting management systems for entire office complexes with thousands of light sources. The new standardisation means that there are no longer any restrictions on the application of this technology. Any light source, including incandescent lamps, fluorescent lamps, high-intensity discharge lamps and even LEDs, can be controlled irrespective of whether they are installed in an office, a restaurant or a street light.

The DALI system is based on simplicity of operation. However the demands on electrical system designers and electricians have increased enormously.

The purpose of this technical manual is to describe how the DALI system components offered by Tridonic operate and illustrate their functionality by looking at how they can be used in actual practice.

DALI stands for "Digital Addressable Lighting Interface" and is an interface protocol for digital communication between electronic lighting equipment (electronic ballasts, transformers, etc.).

The DALI standard was developed by Tridonic together with renowned manufacturers of operating and control equipment. Today, these manufacturers belong to the DALI Activity Group which promotes the use of DALI and safeguards its further development.

The DALI standard was defined in EN 60929 Annex E until 2009 but is now defined in IEC 62386. This standard also describes the differences between the various types of device. As a result, long-term compatibility among manufacturers is guaranteed and the DALI standard is ensured a secure future. In addition, compatibility between products from different manufacturers is supported by a test procedure standardised by the DALI Activity Group. All products that carry the logo of the DALI Activity Group have successfully passed this standardised test. Tridonic products meet these requirements in full.

The DALI protocol was first drafted in the late 1990s. Since November 2014, a new version of the DALI standard is available, the Edition 2 – also called "DALI-2". DALI-2 is the updated and improved version of the DALI lighting protocol, which includes more features and more product types and has a strong focus on product interoperability. Further information about DALI and about the differences between DALI and DALI-2 can be found in the documents "DALI - At a glance" and "Comparison between DALI & DALI-2" (see [Reference list](#), p. 82).

Introduction: DALI standard

1.2. Features of DALI

Feature	Description
Simplified Installation	Power lines and control lines can be laid together in the same cable. The wiring may be in series, in a star arrangement or in mixed form.
No polarity	There is no need to worry about the polarity (+/-) of the DALI control line.
Stable dimming function	All the luminaires receive the same interference-free digital signal and therefore the same dimmer value.
Distributed intelligence	DALI uses a system of distributed intelligence; multiple controllers (e.g. DALI GC) communicate with intelligent ballasts. Each controller operates as a “master” and controls communication on the control line. Ballasts react only as “slaves” at the request of the “master”. Certain parameters are stored directly in the DALI unit (e.g. scene values, group address).
Status feedback	Status reports can be issued by the DALI units. Information on faulty lamps for example can therefore be transferred directly to a higher-ranking system.
Flexibility	Group assignment is set up by means of parameters and not by hard wiring. Lighting scene values are stored in the DALI unit.
Logarithmic dimming curve	The dimming curve is matched to the sensitivity of the eye.

Introduction: DALI standard

1.3. Technical features of a DALI circuit

Parameter	Description
Maximum number of DALI groups	16
Maximum number of DALI scenes	16
DALI voltage	9.5 V - 22.5 V, typically 16 V
DALI system current	Max. 250 mA (depending on the installed DALI power supply)
Data transfer rate	1200 baud
Maximum cable length	The maximum cable length depends on the maximum permitted voltage drop along the DALI cable; this is defined as 2 V max. This corresponds to a maximum cable length of 300 m for a line cross-section of 1.5 mm ² .

CAUTION!

When the maximum cable length is calculated the contact resistance must also be taken into account.

- _ A voltage drop of 2 V must not be exceeded!

1.4. Scene and group concept

1.4.1. DALI scenes

With DALI it is possible to store 16 different lighting scenarios in each DALI unit so that predefined lighting moods can be called up for a room (for example the "presentation" scene in a conference room, or a "morning" scene in a wellness centre). The values of the 16 scenes are stored in the control gear. As soon as the unit receives the command "Go to scene 1" for example it fades up or down to the value stored in memory. The cross-fade time for the scene call is also stored in the unit and can be set in steps between 0.7 and 90.5 seconds with the "Fade Time" parameter.

Introduction: DALI standard

Figure: Examples of light scenes



"Daytime showroom" scene



"Night-time showroom" scene

1.4.2. DALI groups

With DALI it is possible to define 16 groups in a DALI circuit.

A group is a meaningful collection of luminaires. Group assignment can be edited in DALI. It is possible for one DALI unit to belong to several groups. This reduces the amount of wiring needed and greatly increases flexibility compared with non-addressable systems because in these systems the groupings are hard-wired.

1.5. Positioning of DALI

DALI is not a new system for building control such as LON, KNX and other building management systems but a useful addition for the practical application of lighting controllers. DALI provides ideal support for building control systems and enables each light source to be individually addressed. Even small installations in which a building control system would not be economical need not forego the convenience of digital technology. DALI can be used in such installations as an independent lighting management system.

Digital technology has taken over from analogue technology in lighting control systems because of the universal application of DALI units and their reliable control.

DALI controllers of comfortDIM product series

2.1. DALI controllers of comfortDIM product series

The unique comfortDIM concept is the basis for extremely user-friendly lighting solutions with enormous flexibility for future expansion. It uses the DALI protocol (Digital Addressable Lighting Interface). This is a standardised protocol that ensures maximum investment protection and future-proofing. It also guarantees security of planning and high levels of flexibility even after set-up.

DALI controllers of comfortDIM product series

Table: Functional overview comfortDIM

	DALI XC (SC/GC mode)	DALI XC (MC mode)	DALI TOUCH- PANEL 02	x/e-touch- PANEL 02	DALI MSensor 5DPI 14 + DALI MSensor 02
Manual group / scene control Groups and scenes can be easily switched and dimmed with the group and scene control modules.	✓	✓	✓	✓	
Multi-functional control These control modules ensure maximum flexibility. The inputs and buttons can be freely programmed for a wide range of functions.		✓	✓		
Automatic scene control (sequence) Predefined lighting scenes can be easily combined into a self-executing sequence.		✓		✓	
Automatic colour control (sequence) Predefined light colours can be easily combined into a self-executing sequence.				✓	
Time-controlled daily processes (scheduler) Predefined scenes, sequences or colours can be controlled or recalled via a real-time clock.				✓	
Automatic daylight and presence control DALI lighting controls supplemented with a sensor module enable energy-efficient solutions to be provided.					✓
Remote control of the DALI circuit Functions can be controlled from an infrared remote control.					✓
Convenient operation and programming Simple set-up of the DALI circuit and convenient operation of the control functions.				✓	
Convenient configuration with a PC DALI systems can be easily configured by means of an interface module and PC software. Even complex systems can be easily set up.		✓	✓		✓
Manual colour temperature control Tunable white devices can be controlled.			✓	✓	

DALI controllers of comfortDIM product series

2.1.1. DALI power supply DALI PS1 / DALI PS2

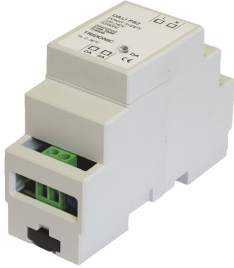

DALI PS1 and DALI PS2 are DALI power supply modules with a rated current of 200 mA (240 mA in the case of DALI PS2). The modules differ in their casing design; DALI PS2 are suitable for installation in switching cabinets; DALI PS1 is suitable for installation in suspended ceilings or cavities.

2.1.2. DALI XC

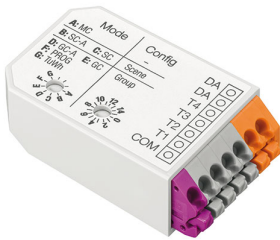

DALI group controllers DALI XC in GC or GC-A mode

Two lighting groups can be controlled with the group controller (ON/OFF/DIM). Set-up (addressing) and assignment to the DALI groups can be performed by means of a simple switch sequence. In the case of the GC-A mode, configuration via the switches is disabled to prevent unintentional reprogramming. The compact design enables the unit to be installed in a standard switch box.

DALI scene controllers DALI XC in SC or SC-A mode

The scene controller enables four lighting scenes to be programmed and recalled. In the case of the SC-A version, configuration via the switches is disabled to prevent unintentional reprogramming. The compact design enables the unit to be installed in a standard switch box.

DALI multicontroller DALI XC in MC mode

DALI MC has 4 inputs, the functions of which can be freely edited. Via the settable switching modes (short, long press; toggle; relay mode) a maximum of two options can be assigned to each input, of which one function can be activated in each case.

Customer-specific programming is possible via the masterCONFIGURATOR (see [Reference list](#), p. 82) configuration software. The compact design enables the unit to be installed in a standard switch box.

DALI controllers of comfortDIM product series

2.1.3. DALI TOUCHPANEL



The DALI TOUCHPANEL 02 has selectable control panel functions for manual control of DALI lighting groups and DALI lighting scenes. Customer-specific programming is possible via the masterCONFIGURATOR (since version 2.6) (see [Reference list](#), p. 82).

2.1.4. DALI x/e-touchPANEL 02

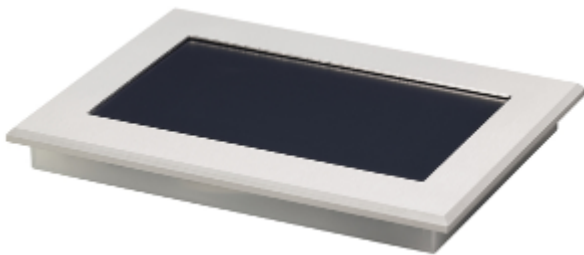

The x/e-touchPANEL 02 with its 7 inch colour touch screen is a lighting management system for up to 128 DALI units. The x/e-touchPANEL 02 contains user-friendly application software with a mode optimised for RGB colour lighting management.

2.1.5. DALI MSensor 5DPI 14 / DALI MSensor 02



The DALI MSensor is a DALI-based sensor with ambient light control and presence detection. The DALI MSensor also has a receiver for infrared remote control. There are versions for installation in luminaires, ceilings and boxes and also for surface mounting.

DALI controllers of comfortDIM product series

2.1.6. REMOTECONTROL IR6

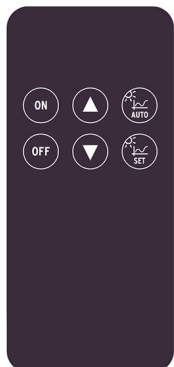

These remote control extend the functionality of the DALI MSensor. With the user-friendly REMOTECONTROL IR6 it is also possible to perform all the basic functions of the DALI MSensor.

2.1.7. DALI USB



The DALI USB interface module enables the DALI installation to be set up and parametrised with the aid of a PC. Tridonic offers therefore the software masterCONFIGURATOR (see [Reference list](#), p. 82) to make it easier to put even complex DALI installations into operation.

2.1.8. DALI RS232 Interface PS/S



The DALI RS232 Interface PS/S combines a DALI interface module and a power supply module in one and the same device. The rated current of the power supply is 240 mA. Via the RS232 interface it is possible to put the DALI system into operation and to set its parameters. During normal operation the interface can be used for service purposes. The RS232 interface is accessed via an RJ45 socket. An optional connecting cable from the RJ45 socket to an RS232 plug is available as an accessory. Additional adapters (to USB for example) are available from various manufacturers.

DALI interface modules

2.2. DALI interface modules

2.2.1. DALI RM/S 4x10A



The DALI-RM/S 4x10A enables switching of 4 independent switching loads via DALI. Lamps and other electronic users with a mains voltage of 230 / 240 V_{AC} can be integrated in a DALI circuit.

2.2.2. DALI RM



The DALI RM relay module controller enables a contactor (12/24 V_{DC} or 230V_{AC}) to be controlled so that different loads can be switched via DALI commands.

DALI devices

2.3. DALI devices

2.3.1. Electronic LED control gear

Tunable White Components / Systems



To simulate daylight in a manner that is as true to nature as possible, light from cool white and warm white LEDs covering the entire colour palette from 2,700 to 6,500 Kelvin is mixed together. A driver with intelligent technology and a wide dimming range of 3% to 100% are the basis of the Tunable White system. Pre-calibrated kits ensure that colour tolerances are balanced out and the colorimetric locus remains constant across all modules and dimming levels. Suitable control and operating elements from Tridonic, ranging from simple button controls through wireless control and all the way to integration in DALI systems, round off the system perfectly.

DALI drivers with one4all interface (linear, compact, stretched compact, Outdoor, Intrack)



The LED control gear with one4all interface are dimmable constant current or constant voltage control gear. There are built-in versions (linear and compact) and remote versions (compact with tool-less strain relief, strain relief optionally available) as well as Outdoor, Industry and Intrack.

The LED control gear with one4all interface has the option to control via DALI, DSI (not all drivers support DSI) or switchDIM and automatically adjusts to the control signal. The control gear has various functions that can be set via DALI. Details can be found in the product data sheet or in the manual.

2.3.2. Electronic Fluorescent control gear

PCA EXCEL one4all xitec II



DALI devices

PCA EXCEL one4all Ip xitec II and PCA ECO Ip xitec II are digital dimmable electronic control gear for fluorescent lamps. PCA EXCEL one4all Ip xitec II has the option of control via DALI, DSI, switchDIM or SMART and automatically adjusts to the control signal. It also has a large number of intelligent functions and is therefore suitable for a wide range of applications. PCA ECO Ip xitec II has the option of control via DALI, DSI, switchDIM and SMART and is designed for use in building management systems.

PCA ECO Ip xitec II

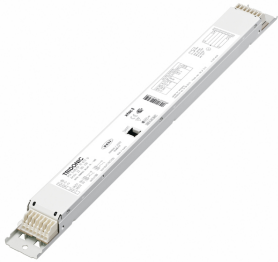

PCA ECO Ip xitec II is digital dimmable electronic control gear for fluorescent lamps. PCA ECO Ip xitec II has the option of control via DALI, DSI, switchDIM and SMART and is designed for use in building management systems.

2.3.3. Phase dimmers

DALI PCD 300 one4all G2



DALI PCD 300 one4all is a digital leading-edge and trailing-edge phase dimmer for ceiling installation. They enable equipment such as electronic or magnetic transformers for low-voltage halogen lamps or incandescent lamps to be integrated in a DALI system. Connected load for DALI PCD 300 one4all: 30 VA – 300 VA.

2.3.4. LED control gear for emergency lighting

EM powerLED PRO 1-4 W emergency lighting control unit + LED emergency lighting modules



LEDs are ideally suited for use in escape sign, escape route and anti-panic luminaires. In this field, Tridonic offers a wide range of LED modules for emergency lighting operation that boast impressively high system efficiency. Optics that are optimised for the respective application guarantee high illuminance levels combined with extremely compact dimensions. Solutions for application-specific emergency lighting.

DALI devices

Emergency lighting LED Driver with DALI interface and automatic test function.

EM converterLED PRO emergency lighting LED Driver + LED modules for general lighting



In the universal system, the LED modules that are also used for general lighting are switched by means of the emergency lighting control gear in case of an emergency. This solution offers maximum flexibility: it is compatible with all LED modules and all LED gear components made by Tridonic and other manufacturers. Universal solution for all LED modules.

DALI interface for controlled testing and monitoring.

EM powerLED PRO emergency lighting control units for higher LED-power + LED modules for general lighting



The combined emergency lighting LED Driver EM powerLED (80W Ip, 50W/45W C, SR) LED emergency lighting control units are the ideal solutions for a cost-optimised structure of the emergency lighting installation. They integrate the LED Driver for mains operation and the emergency lighting function in one assembly. Combined solution for normal and emergency lighting operation.

Emergency lighting LED Driver with DALI interface and automatic test function.

LED Light Engine EM ready2apply



The EM ready2apply PRO is the ideal solution for simple emergency lighting design. Thanks to the fusion of the LED driver and the LED module in combination with a long-lasting lithium-iron phosphate (LiFePO₄) battery, the unit is immediately ready for use. LED Light Engine for emergency lighting operation maintained and non-maintained

DALI interface and automatic test function

Miscellaneous

2.4. Miscellaneous

2.4.1. DALI Repeater



The DALI Repeater is an amplifier module for refreshing the DALI signal. With the DALI Repeater it is possible to increase the maximum length of the DALI control line from 300 m to 600 m.

comfortDIM product series in detail

This chapter provides details of the various comfortDIM products. The topics covered here include functions, connections and programming. For further information on the products please refer to the data sheets and the installation instructions.

3.1. DALI power supply

3.1.1. DALI PS1/ PS2



DALI PS1 and DALI PS2 are DALI power supply modules with a rated current of 200 mA or 240 mA (DALI PS2). The modules differ in their casing design; DALI PS2 are suitable for installation in switching cabinets; DALI PS1 is suitable for installation in suspended ceilings or cavities.

The interface of a DALI ballast needs a maximum of 2 mA; for 64 individual addresses this means a current of 128 mA. The remaining 72 mA (or 112 mA in the case of DALI PS2) can be used for supplying DALI control modules without their own power supply (DALI XC, etc.).

DALI power supply

3.2. DALI XC

3.2.1. Overview

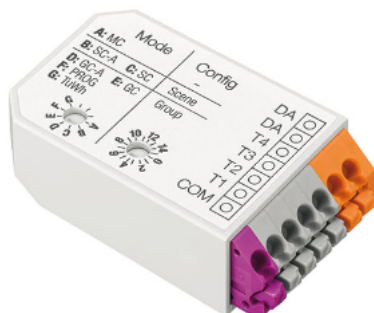

The DALI XC is a push button module with 4 push button inputs. Its compact design means that DALI XC can be installed together with the standard momentary switches in a flush-mounted box, so set-up of the DALI circuit can be decentralized. It is also possible to control the inputs of the DALI XC via relays. Depending on the application, the DALI XC can be operated in different modes.

Position of rotary switch	Function	Description
A	MC	Multi controller mode
B	SC-A	Scene controller
C	SC	Scene controller without programming possibility
D	GC-A	Group controller
E	GC	Group controller without programming possibility
F	PROG	Only programming mode
G	TuWh	Tunable White mode

The mode is selected using the "Mode" rotary switch on the DALI XC.

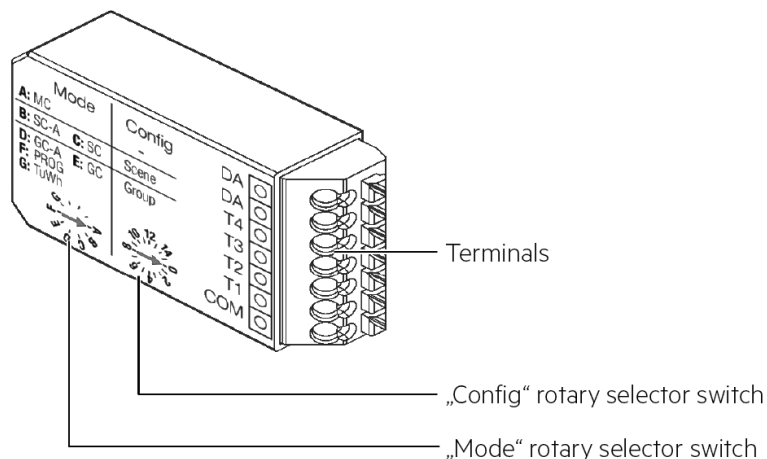

DALI group controllers: DALI XC in GC & GC-A mode

The DALI XC module is multi-master-compatible so several control modules can be used in a DALI circuit.

3.2.2. Connection

The DALI XC switch module is connected directly to the DALI control line and does not need a separate power supply. It is powered via the DALI circuit (current draw = 6 mA). It can be connected to the DALI circuit with either polarity. To control either a single momentary switch or multiple momentary switches can be used.

Figure: DALI XC momentary switch connection

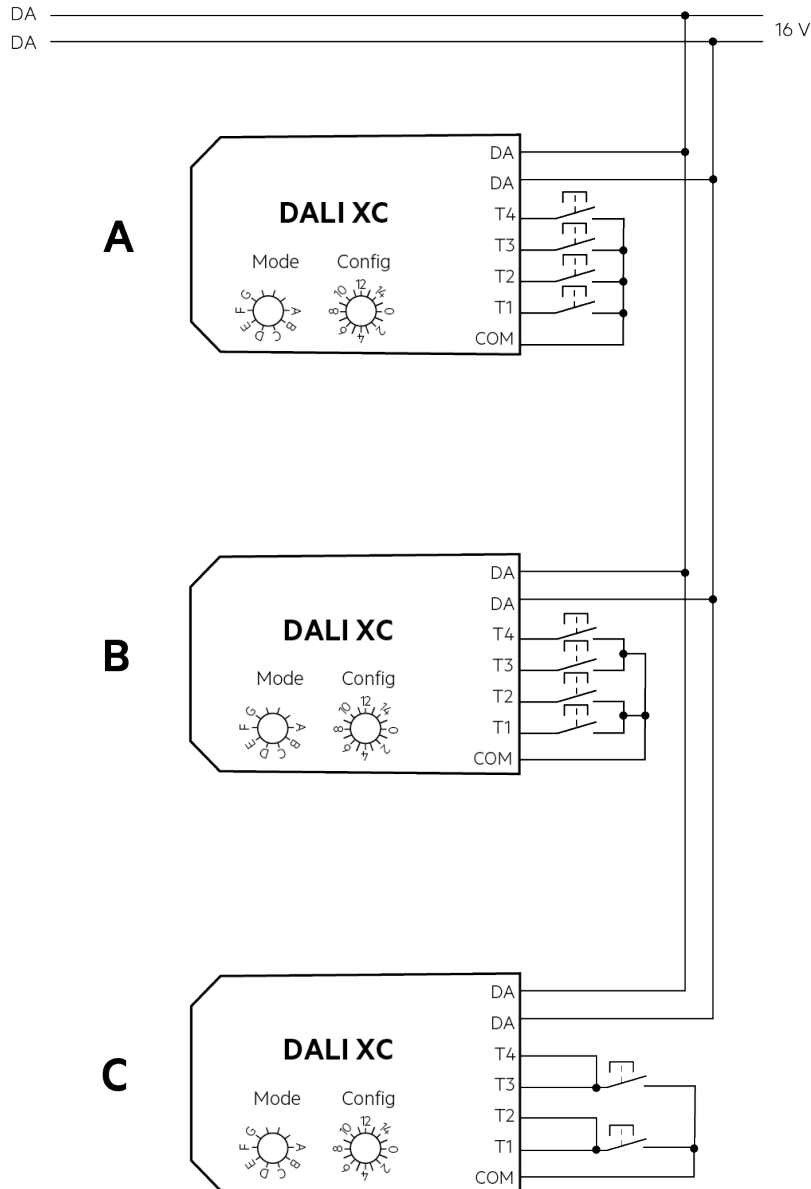

⚠ CAUTION!

The DALI circuit is not SELV. This means that the switches and cabling must be suitable for mains voltage.

- _ The connection leads between the momentary switches and the DALI XC must not be lengthened!

DALI group controllers: DALI XC in GC & GC-A mode

3.2.3. DALI group controllers: DALI in GC & GC-A mode

Description

DALI XC in GC mode is a module that enables dimming commands to be sent to two groups (groups A and B) on the DALI circuit. Any standard momentary switch can be connected to the module. Its compact design means that DALI XC in GC mode can be installed together with the standard momentary switches in a flush-mounted box, so set-up of the DALI circuit can be decentralized. Either individual switches or UP/DOWN switches can be used for controlling the groups. The controlled groups are set on a rotary switch on the module.

The DALI XC in GC mode module is multi-master-compatible so several control modules can be used in a DALI circuit. It is also possible to address and group simple DALI circuits with the aid of DALI XC in GC mode.

DALI XC in GC-A mode is similar to DALI XC in GC mode. The only difference is that the programming mode is not activated in DALI XC GC-A mode. This prevents the DALI units from being reprogrammed unintentionally via the switches.

Basic functions

Switch group on

- _ Connect standard momentary switch (single switch or double switch) to the DALI XC
- _ Press single momentary switch or UP button of double momentary switch briefly
 - > Luminaires will be dimmed to maximum
 - > Group is switched on

Switch group off

- _ Press single momentary switch or UP button of double momentary switch
 - > Luminaires will be switched off
 - > Group is switched off

Dimm groups

- _ Hold down single momentary switch or UP/DOWN button of double momentary switch
 - > Luminaires will be switched on (if they were switched off before)
 - > Luminaires will be dimmed

Overview of switch functions

Table: Momentary switch functions double momentary switch

Depress time UP button	Depress time DOWN button	Function
40 to 300 ms		On to max
	40 to 300 ms	Off
> 300 ms	> 300 ms	On (if necessary) / dim

DALI group controllers: DALI XC in GC & GC-A mode

Table: Momentary switch functions single switch

Depress time single switch	Function
40 to 300 ms	On to max / Off
> 300 ms	On (if necessary) / dim

Group assignment

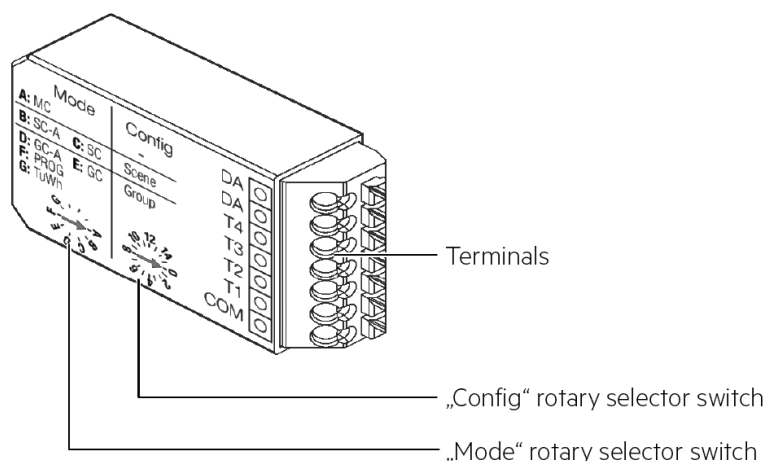

The "config" rotary switch on the front of the module is used for group assignment. The switch setting shown corresponds to group A. Group B is the group immediately following group A.

Table: Group assignment

Rotary switch setting	Group switch 1	Group switch 2
0	Broadcast	1
1	1	2
2	2	3
3..9	3..9	4..10
A..F	10..15	11..16

Example:

Rotary switch setting = 3, therefore:
 Switch 1 = group 3, switch 2 = group 4

Programming

With the DALI-XC it is also possible to address and configure simple DALI installations. The programming mode is not integrated in GC-A so there is no chance of reprogramming the DALI units by mistake via the momentary switches.

DALI group controllers: DALI XC in GC & GC-A mode

Start programming mode without deletion of addresses (expansion of the system)

- _ Connect standard momentary switch to DALI XC
- _ Choose a button and hold down (>10 s)
-> A beep will sound
- _ Release button briefly (1 s)
-> A beep will sound again
- _ Hold button down (1 s)
-> Two beeps will sound
- _ Release button
-> Device switches to programming mode
-> Current settings (group assignment) won't be deleted

Figure: Programming mode without deleting the addresses

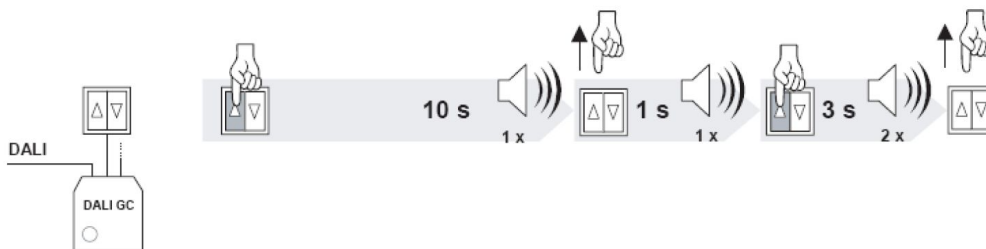

Start programming mode with deletion of addresses (new installation)

- _ Connect standard momentary switch to DALI XC
- _ Choose a button and hold down (>10 s)
-> A beep will sound
- _ Release button briefly (1 s)
-> A beep will sound again
- _ Hold button down (>3 s)
-> Two beeps will sound (after 1 s)
-> Three more beeps will sound (after 3 s)
- _ Release button
-> Device switches to programming mode
-> Current settings (group assignment) will be deleted

Figure: Programming mode with deletion of addresses

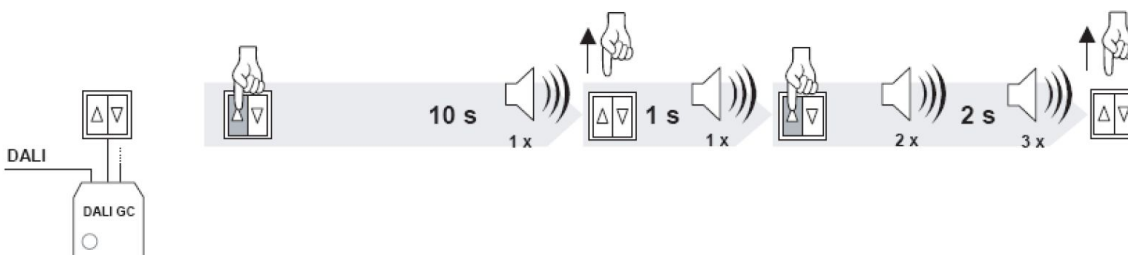

DALI group controllers: DALI XC in GC & GC-A mode

i NOTICE

In programming mode the system first searches for available DALI devices in the DALI circuit. The devices are addressed as follows:

- _ In programming mode with deletion all devices will be automatically addressed
- _ In programming mode without deletion only newly detected devices are addressed

During the search operation all the detected luminaires are faded to maximum. When the search has been completed one luminaire (the one selected) will remain at maximum and all the others will be faded to the lowest value.

Selecting luminaires

To attach a luminaire to a group, the luminaire must be selected first.

- _ Choose a button of the momentary switch
- _ Press button briefly to select a luminaire
 - > Selected luminaire is faded to maximum
 - > All other luminaires are dimmed to minimum
- _ Press button again to select another luminaire

i NOTICE

A single luminaire can contain more than one device. If this is the case all devices in the luminaire must be selected separately.

The luminaires are selected in the sequence in which they are found. When you come to the last luminaire in the sequence, the next one selected will be the first luminaire in the sequence again. A selected luminaire can now be assigned to a group.

Assigning a selected luminaire to a group

If a luminaire is assigned to a certain group it reacts to fade commands that come from momentary switches of the same group. The group assigned can be stored in the selected DALI device.

- _ Make sure that the right luminaire is selected
- _ Choose a button that is assigned to the right group
- _ Hold button down (>3 s)
 - > A beep will sound
 - > The group assigned will be stored in the DALI device
 - > Luminaire will react to fade commands coming from the chosen button

The group assigned to a switch (rotary switch setting) can be stored in the selected DALI device by pressing the appropriate momentary switch (for longer than 3 seconds; you will hear a beep). This means that the luminaire will then react to fade commands from this momentary switch.

DALI group controllers: DALI XC in GC & GC-A mode

Figure: Group assignment

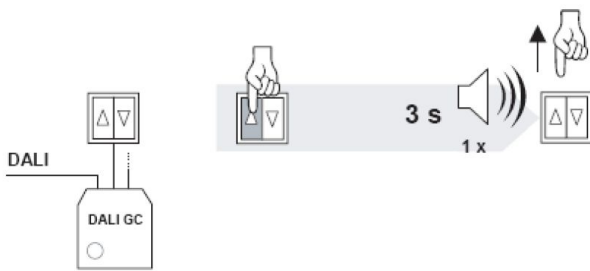

Removing a luminaire from a group

- _ Make sure that the right luminaire is selected
- _ Choose a button that is assigned to the right group
- _ Hold button down (>6 s)
 - > First beep will sound (after 3 s)
 - > Second beep will sound (after another 3 s)
 - > The group assigned of the button will be deleted
 - > Luminaire will not react anymore to fade commands coming from the chosen button

Figure: Removing a luminaire from a group

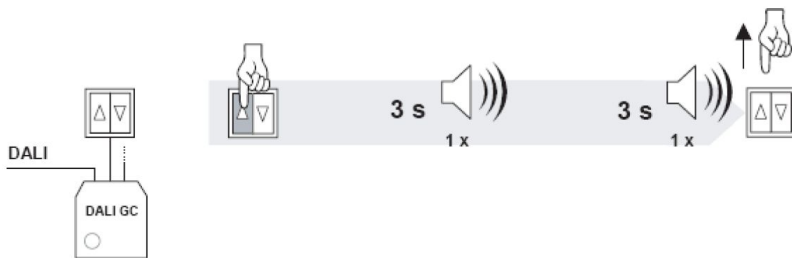

Finish programming mode

- _ Hold button down (>9 s)
 - > First beep will sound (after 3 s)
 - > Second beep will sound (after another 3 s)
 - > Third beep will sound (after another 3 s)
- _ Release button
 - > Programming mode is finished
 - > All buttons in the system are back in their normal state

Figure: Finish programming mode

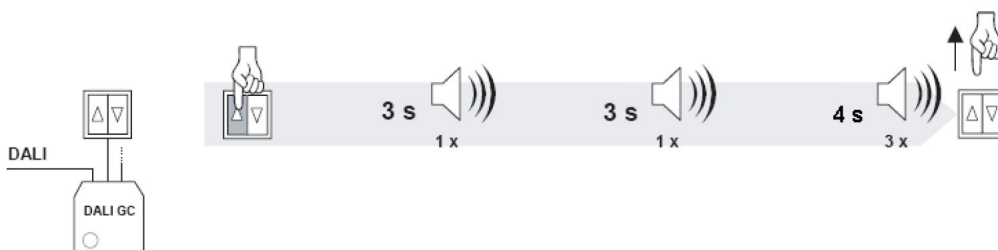

DALI group controllers: DALI XC in GC & GC-A mode

Example: Multiple independent small offices on the same DALI line

Requirement

- _ On/off switching via switches
- _ Dimming of two groups (window luminaires and corridor luminaires)

Figure: Overview of a small office set-up (left room A / right room B)

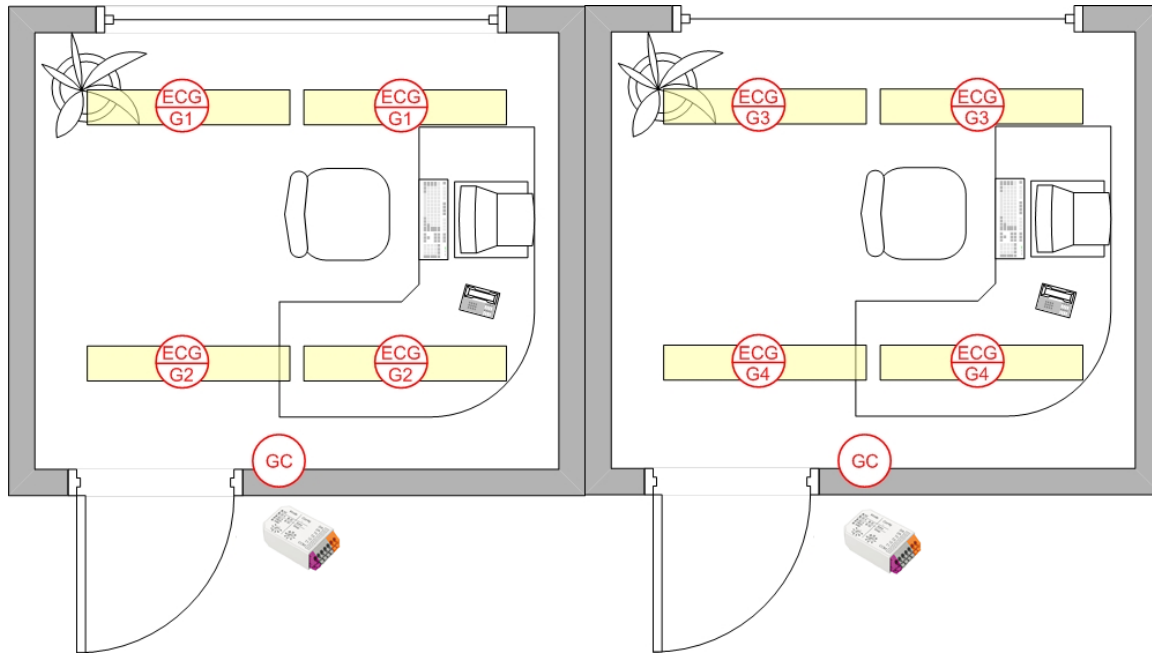

Table: DALI XC in GC mode

	Room A	Room B
Window group	Group 1	Group 3
Corridor group	Group 2	Group 4
DALI GC	Rotary switch setting 1 (Groups 1+2): Group 1 => Switch for window row Group 2 => Switch for corridor row	Rotary switch setting 3 (Groups 3+4): Group 3 => Switch for window row Group 4 => Switch for corridor row

DALI scene controllers: DALI XC in SC & SC-A mode

3.2.4. DALI scene controllers: DALI XC in SC & SC-A mode

Description

DALI XC in SC mode enables scene selection commands for up to four scenes to be sent to the DALI circuit. Any standard momentary switch can be connected to the module. The scenes are set on a rotary switch on the module.

The DALI XC in SC mode is multi-master-compatible so several control modules can be used in a DALI circuit.

The SC-A mode is similar to the SC mode. The only difference is that the programming mode is not activated in SC-A mode. This prevents the DALI units from being reprogrammed unintentionally via the momentary switches.

Basic functions

Retrieve scene

- _ Press momentary switch briefly
-> The scene which is assigned to the momentary switch will be retrieved

A scene is assigned to each of the four momentary switches. The scene selections are broadcast to all the luminaires on the DALI circuit.

Table: Switch function

Switch depression	Function
40 ms...1 s	Selection of the scene assigned to the switch

Scene assignment

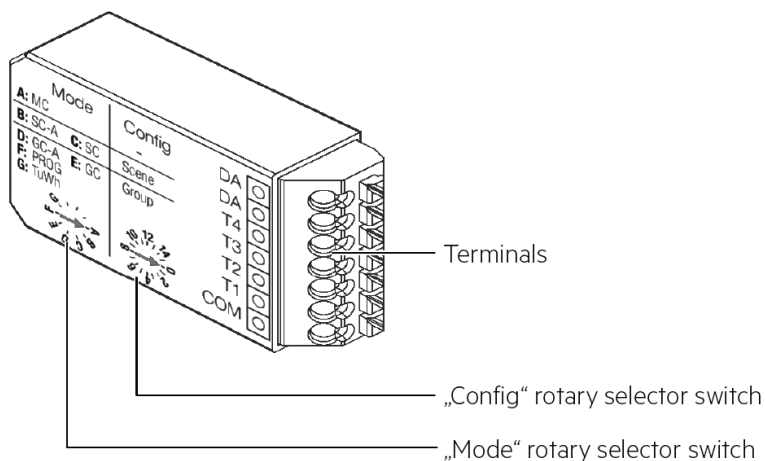

The "config" rotary switch on the module is used for scene assignment. The switch setting shown corresponds to scene A. Scenes B, C and D immediately follow scene A.

DALI scene controllers: DALI XC in SC & SC-A mode

Table: Scene assignment

Rotary switch setting	Scene switch 1	Scene switch 4	Scene switch 3	Scene switch 4
1	1	2	3	4
2	2	3	4	5
3	3	4	5	6
4...9	4...9	5...10	6...11	7...12
A...F	10...15	11...16	12...1	13...2
0	16	1	2	3

Example:

Switch setting = 3, therefore:

Switch 1 = scene 3, switch 2 = scene 4, switch 3 = scene 5, switch 4 = scene 6

Programming

Save scene

- _ Hold down momentary switch (>10 s)
-> A beep will sound
- _ Press momentary switch (1 s)
-> Current light value of all luminaires will be stored as scene value
-> Scene number of the momentary switch will be assigned to the scene
-> Scene can be activated with the chosen momentary switch

NOTICE

The light value can be changed with any DALI control (e.g. DALI XC in GC mode).
The programming mode is not integrated in the SC-A mode so there is no chance of reprogramming the DALI units by mistake via the switches.

DALI scene controllers: DALI XC in SC & SC-A mode

Figure: Scene assignment

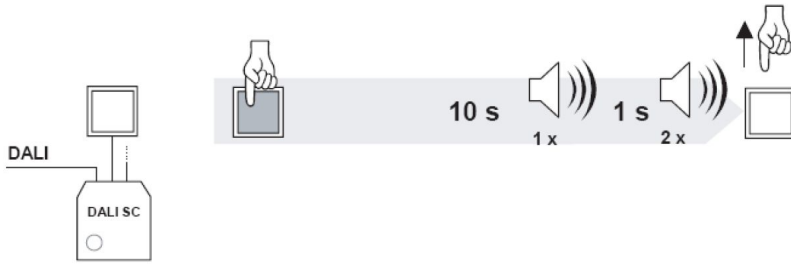

Example: Conference room

Requirement

- _ On/off switching via switches
- _ Dimming of two groups (linear luminaires and low-voltage halogen spotlights)
- _ Retrieval of user-defined lighting scenes (e.g. the presentation scene)

Figure: Overview of a conference room set-up

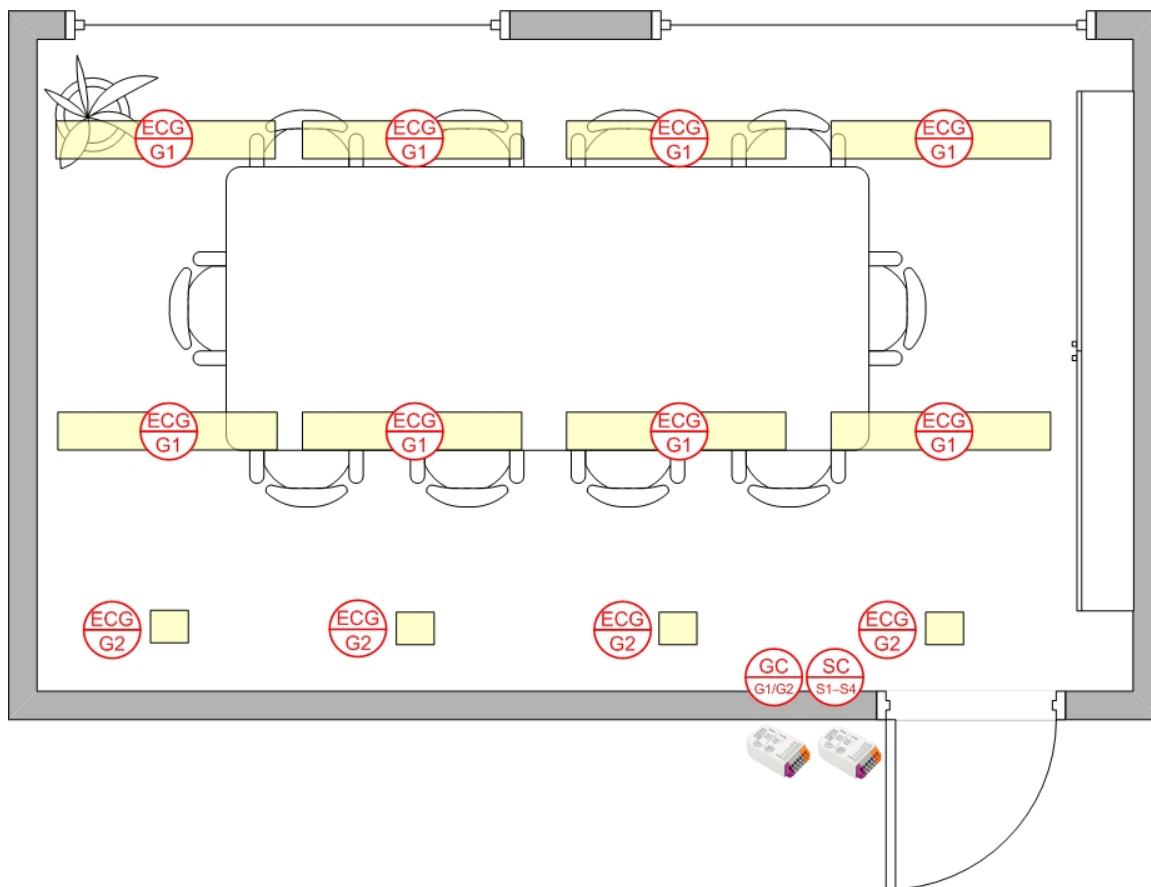

DALI scene controllers: DALI XC in SC & SC-A mode

Table: DALI XC 1x GC mode and 1x SC mode assignment

	Conference room
Linear luminaires	Group 1
Halogen spotlights	Group 2
DALI XC - GC mode	Rotary switch setting 1 (Groups 1+2): Group 1 => Switch for linear luminaires Group 2 => Switch for halogen spotlights
DALI XC - SC mode	Rotary switch setting 1 (Scenes 1-4): Scene 1 => Light off Scene 2 => Light 100% Scene 3 => Presentation Scene 4 => Meeting

DALI multi controller: DALI XC in MC mode

3.2.5. DALI multi controller: DALI XC in MC mode

Description

The DALI XC in MC mode is a multifunctional control module for the DALI circuit. It has four independent inputs with freely configurable functions.

There is also the option of providing a power supply monitoring system with the DALI XC in MC mode. When the power supply returns a predefined lighting status is retrieved.

The four inputs are configured by means of masterCONFIGURATOR (see [Reference list](#), p. 82).

Function

The behaviour of each of the four inputs can be defined with the aid of the masterCONFIGURATOR software. Possible settings are:

The input functions as

- _ a push to make switch
- _ a standard switch
- _ a changeover switch
- _ a stairwell switch
- _ a push to make switch that calls up a predefined sequence of DALI commands (macro)

In addition to defining the function you can set further parameters to select the destination address for which the function is intended (broadcast, group or individual address) and the type of DALI command to be performed.

Example: On/off switch

Parameter	Description
Destination address	Group 1
Function	Switch
DALI command	“Recall max. Level” when switched on and “OFF” when switched off

Configuration by masterCONFIGURATOR

The masterCONFIGURATOR has its own separate documentation (see [Reference list](#), p. 82).

The MC operating mode can only be configured using the masterCONFIGURATOR software versions 2.10 and higher. The device does not function in MC operating mode by default. Detailed informations available in the masterCONFIGURATOR documentation.

DALI multi controller: DALI XC in MC mode

Example: Conference room with DALI MSensor and DALI XC

Requirement

- _ Switch on via momentary switch
- _ Switch off via motion detector (off-only function)
- _ Daylight-dependent control of illuminance
- _ Retrieval of user-defined lighting scenes (e.g. the presentation scene)

Figure: Overview of a conference room set-up

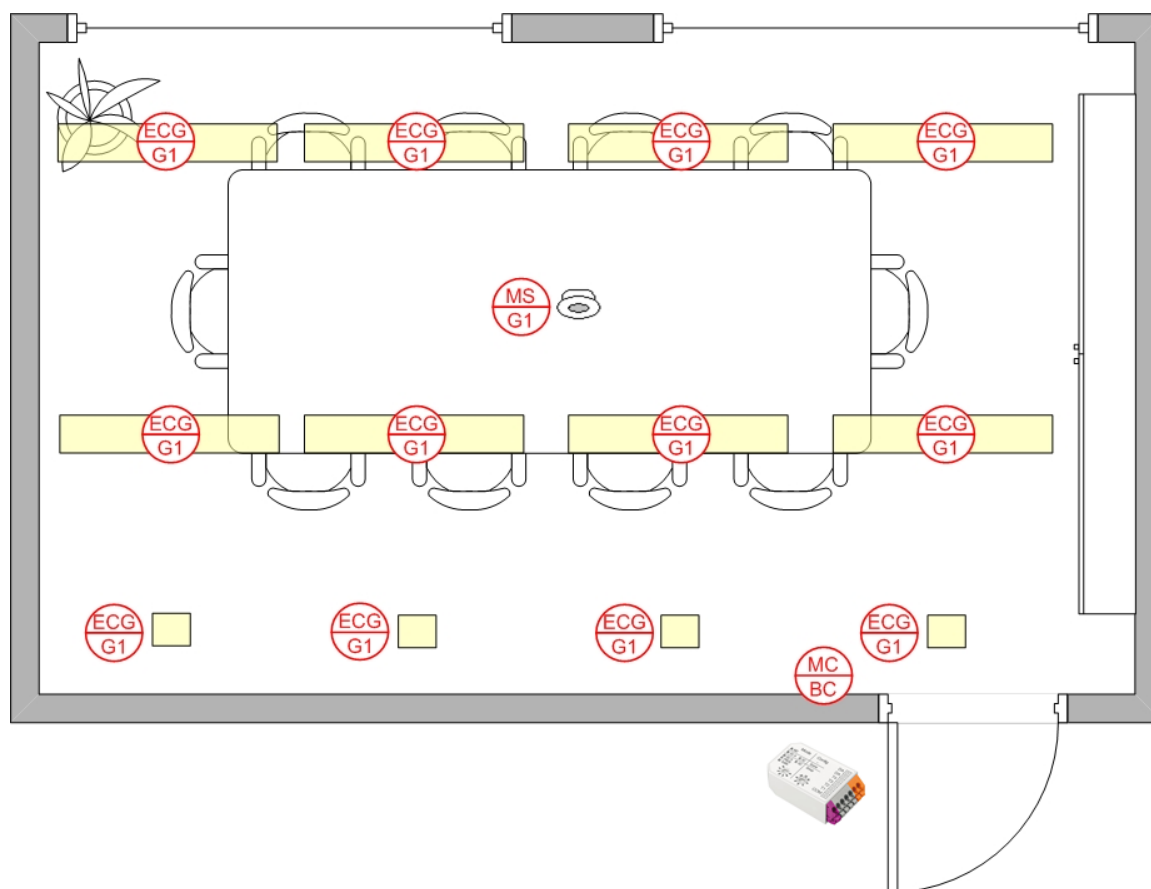

DALI multi controller: DALI XC in MC mode

Table: Assignment of DALI MSensor and DALI XC

Controls	Assignment
DALI MSensor	Luminaire group: Group 1 Rotary switch setting 1 (Groups 1):
DALI XC	Input 1: Destination address: Broadcast Function: Macro 2: MSensor automatic Inputs 2-4: Destination address: Broadcast Function: Button Command: Go to Scene 1-3

DALI TOUCHPANEL 02

3.3. DALI TOUCHPANEL 02

3.3.1. Description



The DALI TOUCHPANEL 02 is a multi-functional device for the DALI circuit. It combines the functions of DALI XC in GC and SC mode in a single module and has six freely definable buttons. The six buttons are configured using the masterCONFIGURATOR (since V2.6) (see [Reference list](#), p. 82).

The following configurations are possible:

- _ On/off switching of individual addresses, groups or broadcast
- _ Up/down fading of individual addresses, groups or broadcast
- _ Scene selections

The DALI TOUCHPANEL 02 offers a high degree of design flexibility. The user interface can be customized with interchangeable layout cards.

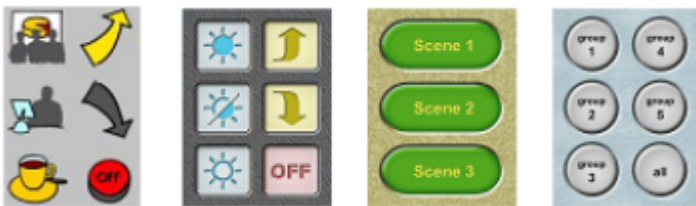

The DALI TOUCHPANEL 02 is multi-master-compatible, which means that several control modules can be installed in parallel in a DALI system.

Via the software masterCONFIGURATOR (since V2.6) it is possible to configure the panel for tunable white applications. The layout is configurable to control individual addresses, groups or broadcast.

DALI TOUCHPANEL 02



3.3.2. Connection

The DALI TOUCHPANEL 02 is connected directly to the DALI circuit and does not need a separate power supply. It is powered via the DALI circuit (current draw = 6 mA in normal operation and 10 mA in service mode). It can be connected to the DALI circuit with either polarity.

3.3.3. Basic functions

Figure: Button assignments of the factory layout

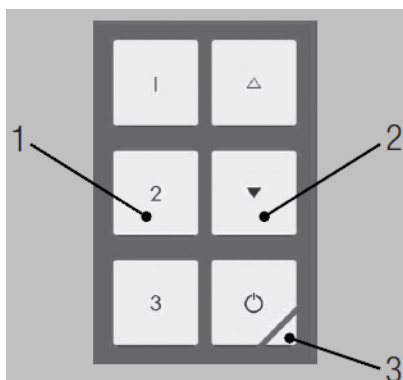

1) **Scene buttons:**

Calling up scenes 1-3

2) **Group buttons:**

Controlling assigned DALI devices or DALI groups.

Short press: ON, OFF

Long press: Dimming

3) **Finder LED:**

Red LED to find the panel in the dark.

Long press: LED on/off

DALI TOUCHPANEL 02

Figure: Button assignments of the tunable white layout

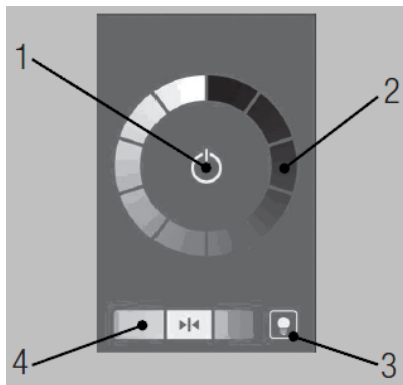

1) On-/Off button:

Turning the Light on or OFF

2) Dim wheel:

Recall of discrete dim values by pressing on any position of the dim wheel. Dimming by sliding along the dim wheel.

3) Finder LED:

Red LED to find the panel in the dark.

Long press: LED on/off

4) Tunable White button:

Change of the colour temperature along the planckian locus via the buttons on the right and left side. Adjusting to 4,500 K by pressing the button in the middle.

3.3.4. Configuration by software

The masterCONFIGURATOR (since V2.6) software can be used to assign each of the buttons on the DALI-TOUCHPANEL 02. The DALI circuit can also be configured with the masterCONFIGURATOR (addressing, grouping, etc.). In addition to the masterCONFIGURATOR (since V2.6) software you will need a DALI USB for the connection between the computer and the DALI circuit.

The masterCONFIGURATOR has its own separate documentation (see [Reference list](#), p. 82).

Table: Parameters for the dimming mode

Dimming mode selection	Short press	Long press
Toggle ON/OFF	Toggles between the selected ON command and OFF command	
Dim up only	Ignored	On (if necessary) / fade up
Dim up and on for short press	Perform the selected ON command	On (if necessary) / fade up
Dim down only	Ignored	Fade down
Dim down and off for short press	Perform the selected OFF command	Fade down
Toggle up/down	Ignored	Toggle between fade up and fade down
Toggle up/down and on/off for short press	Toggles between the selected ON command and OFF command	Toggle between fade up and fade down

DALI TOUCHPANEL 02

NOTICE

Selecting ON or OFF in dimming mode not only allows you to switch the lighting on or off, you can also select which specific command for ON or OFF will be sent. ON and OFF are therefore variables.

Example: Configuring the scene 1 button

Parameter	Description
Logical address	Broadcast
Dimming mode	toggle ON/OFF
ON/OFF command	ON command: "Go to scene 1" / OFF command: "Go to scene 1"

Each time the button is pressed the command "Go to scene 1" is sent.

3.3.5. Example: Conference room Requirement

Requirements

- _ On/off switching at the door
- _ Dimming of all the lights (broadcast) at the control panel near the window
- _ Retrieval of user-defined lighting scenes (e.g. the presentation scene) at the control panel near the window

Figure: Overview of a conference room set-up

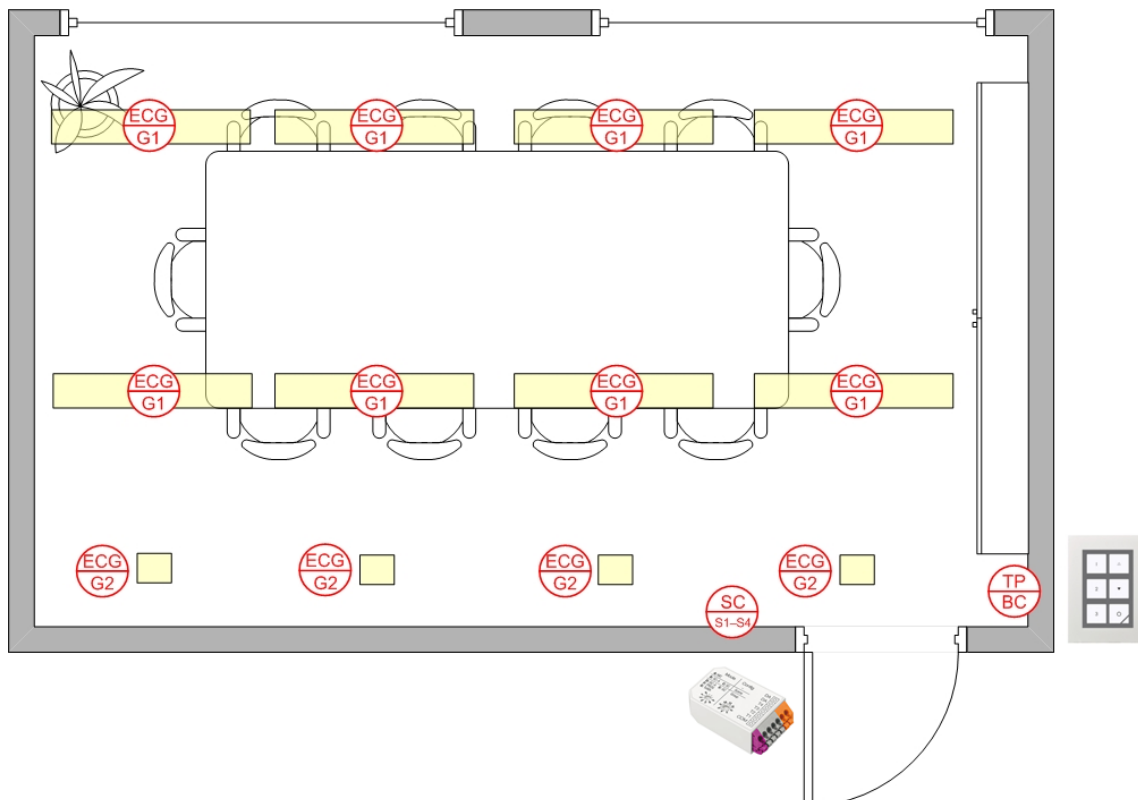

DALI TOUCHPANEL 02

Table: DALI XC (SC mode) and TOUCHPANEL assignment

	Conference room
Linear luminaires	Group 1
Halogen spotlights	Group 2
DALI XC (SC mode) (control panel near door)	Rotary switch position 1 (scene 1-4): Scene 1 => Light off Scene 2 => Light 100% Scenes 3 and 4 => not used
DALI-TOUCHPANEL (control panel near window)	Touchpanel layout 1: Scene 1 => Light off Scene 2 => Light 100% Scene 3 => Presentation Up button => Fade up both groups Down button => Fade down both groups OFF button => Switch off the lighting

DALI x/e-touchPANEL 02

3.4. DALI x/e-touchPANEL 02

3.4.1. Basic, Colour, Plug Operating Modes

Design and functions

In the Basic, Colour and Plug operating mode the x/e-touchPANEL is an operating device and controller for DALI lighting systems. The x-touch software that is controlled using a colour touch-screen is integrated into the x/e-touchPANEL. It is possible to use it in combination with comfortDIM series controllers.

The x-touch software provides the following functions:

- _ Operating modes
 - _ Basic for white light applications
 - _ Colour for RGBW applications
 - _ Plug for simple RGBW applications with preconfigured operating devices where the addressing is already set using coded connectors
- _ Configuration of
 - _ 16 scenes
 - _ 99 light sources
 - _ 7 time-controlled schedules
 - _ 1 calendar-controlled schedule list
 - _ DT 8 (Tunable White)
- _ Real-time clock/calendar
- _ Configuration of the buttons for manual call-up
- _ Design of the buttons for manual call-up
- _ Manual switching and dimming
- _ Frame light and adjustable display light
- _ Communication via interfaces:
 - _ USB
 - _ Ethernet (TCP/IP)

DALI x/e-touchPANEL 02

Table: Properties x/e-touchPANEL

Property	x/e-touchPANEL
Number of DALI lines	2
Connection	Maximum 128 DALI operating devices
Bus supply	External
Interfaces	USB, Ethernet
Frame light	yes
Display light	Always ON or automatically dimmed 2 min. after last activation.

x-touch software

The following explanations will help you understand the x-touch software.

Table: Designation x-touch software

Designation	Meaning
Operating device	DALI operating device
Group (G)	The x-touch software communicates with the operating devices (max. 64 per DALI line) via groups (max. 16). A group can be switched and dimmed individually. Groups can also include EM, HID, LV, INC, CONF or LED devices.
Zone (Z)	Zones are only used in the Colour operating mode. One zone consists of four predefined groups representing the colours red, green, blue and white.
Scene (S)	A scene is used to save a lighting situation defined by the setting of one or several groups.
Sequence (SQ)	Several scenes are saved in a time-specific order in a sequence.
Day plan (SDL)	One or several sequences and/or scenes are saved in a time-specific order in a schedule. A schedule starts automatically every 24 hours at a preset time of the day.
Week plan (SDLL)	Each schedule is assigned to one weekday. In this way, a schedule list is created for the calendar-controlled, uninterrupted automation of lighting situations.
Scheduler	When Scheduler is activated, it appears in the Home menu and enables a sequence, schedule list and schedule to be controlled manually (Start, Pause, Stop and Off).

Basic operating mode

Typical application examples for the Basic operating mode are rooms where mostly white light is used, e.g. public rooms, production halls, restaurants and hotels.

DALI x/e-touchPANEL 02

You can define a maximum of

- _ 16 groups with a total of 128 devices
- _ 16 scenes
- _ 99 sequences
- _ 7 schedules
- _ 1 schedule list

Colour operating mode

All colours of the RGB colour space are the result of the addition of the basic colours red, green and blue (RGB). For a better representation of white light an additional white light source is used (RGBW colour mixing). The colour control of a lighting system is performed in the Colour operating mode. The Colour operating mode is different from the standard Basic operating mode with respect to the grouping of the operating devices.

In the x-touch software, each RGB-/RGBW operating device is assigned to the colour scale (red, green, blue, white) of a zone. Four zones with 4 colour scales are available. The colour scale of a zone corresponds to a group. In the Home menu, the white light can be switched and dimmed via groups 1 to 4.

The table shows the assignment of the 16 groups to the four colours of the individual zones. Zone assignment is automatically controlled by the software.

	W(hite)	R(ed)	G(reen)	B(lue)
Zone 1	1	5	6	7
Zone 2	2	8	9	10
Zone 3	3	11	12	13
Zone 4	4	14	15	16

Typical application examples for the Colour operating mode are rooms where mainly RGBW operating devices are used to implement freely design colour changes and colour effects, e.g. in shop windows, bars and exhibition spaces.

You can define a maximum of

- _ 4 zones with the 4 colours red, green, blue and white with a total of 128 devices
- _ 16 scenes for white light
- _ 8 colour scenes
- _ 99 sequences
- _ 7 schedules
- _ 1 schedule list

Plug operating mode

With the Plug operating mode only one zone is used with the groups 1-4. The groups represent the colours red, green, blue and white. The assignment to a group is done via a connector on the operating device. The classification into scenes is not possible.

DALI x/e-touchPANEL 02

3.4.2. Emergency Operating Mode

Design and functions

Up to 120 DALI emergency units can be controlled and monitored with the x/e-touchPANEL in Emergency operating mode. In addition, the emergency lighting tests prescribed in the relevant standards can be performed automatically. The test results are recorded in a log file for verification.

The x/e-touchPANEL with a colour touch-screen provides the following functions for operating the emergency units:

- _ Addressing and grouping
- _ Identification
- _ Manual tests
- _ Time-controlled function and duration tests
- _ User-friendly software

A frame light is integrated in the x/e-touchPANEL. It supports the status line of the system.

Use with Emergency operating mode

The x/e-touchPANEL in Emergency operating mode may only be used for controlling the emergency lighting of single battery powered emergency lighting systems. It can control a maximum of 120 emergency units.

Only the following emergency lighting modules may be connected:

- _ EM PRO
- _ EM powerLED PRO

3.4.3. Connection

The x/e-touchPANEL 02 is directly connected to the DALI circuit. The DALI x/e-touchPANEL02 has a current draw of 2 mA in the DALI circuit. The unit must be connected to the ac power supply via the supplied power supply unit.

Wiring diagram. Basic, Colour, Plug Application

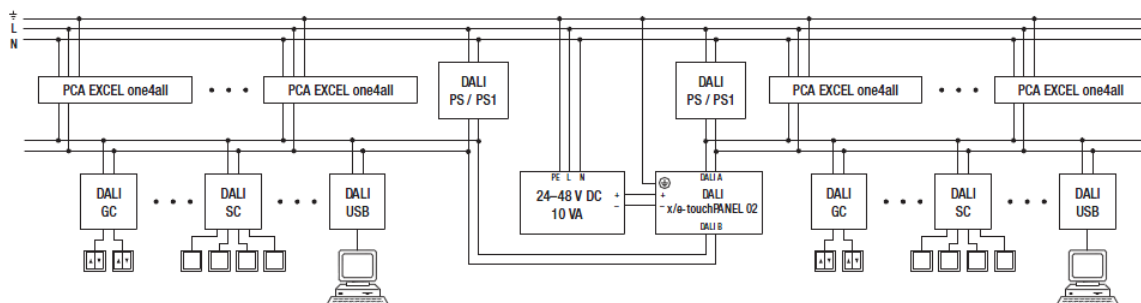

DALI x/e-touchPANEL 02

Wiring diagram: Emergency Application

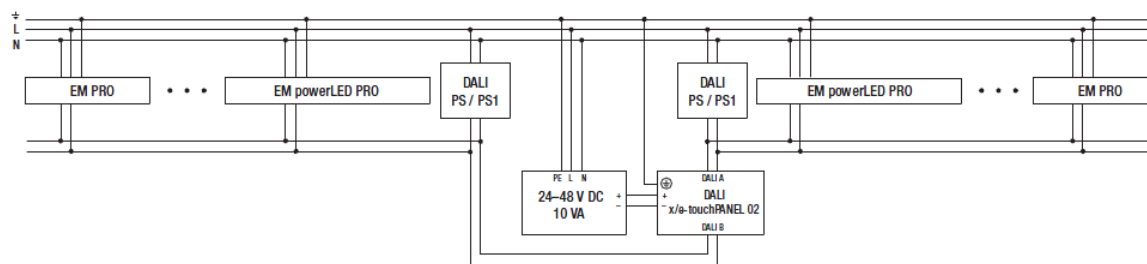

NOTICE

The x/e-touchPANEL 02 needs for each DALI line a separate DALI power supply. For more information on x/e-touchPANEL 02 see the relevant operating instructions and data sheets.

DALI MSensoren

3.5. DALI MSensoren

3.5.1. Description

The DALI MSensor is a digital controller in the comfortDIM product range that can be used to control the control gear of a DALI group collectively. The sensor combines three functions in one control device:

- _ Constant light control
- _ Presence-based control
- _ Remote control

The DALI MSensor 5DPI 14 is available in three different housing designs:



Fitted in luminaire white



Fitted in luminaire black



Recessed into ceiling

The DALI MSensor 02 is available in four different housing designs:



Fitted in luminaire

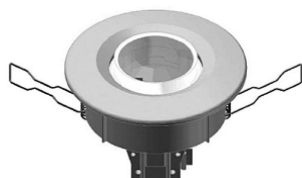

Recessed into ceiling



Surface-mounted

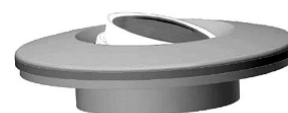

Box-mounted

The DALI MSensor is designed for the following principal applications:

- _ Individual offices
- _ Open-plan offices
- _ Training/presentation rooms
- _ Corridors, passageways and garages

The DALI MSensor either controls all the units on the DALI circuit or a DALI group. The DALI MSensor is Multi-master compatible, i.e.

DALI MSensoren

it can be used in conjunction with other DALI controllers in the comfortDIM product range. This allows the DALI MSensor to be addressed and grouped in the same way as DALI control gear and makes it easy to configure the system.

The DALI MSensors is configured in the masterCONFIGURATOR software (V2.02. or later) (see [Reference list](#), p. 82).

3.5.2. Connection

The DALI MSensor is connected directly to the DALI circuit and does not need a separate power supply. It is powered via the DALI circuit (current draw = 6 mA). It can be connected to the DALI circuit with either polarity.

3.5.3. Functions

The DALI MSensor has the following functions and user interfaces:

- _ Constant light control by means of ambient light sensor
- _ Presence-based control by means of PIR motion sensor or presence detector
- _ Remote control via an infrared input for two different IR remote controls

3.5.4. Individual office rooms

Requirements

- _ Switch on and switch off by means of momentary-action switch
- _ Switch off by means of motion sensor
- _ Ambient light control of illuminance

Figure: Overview of individual office rooms

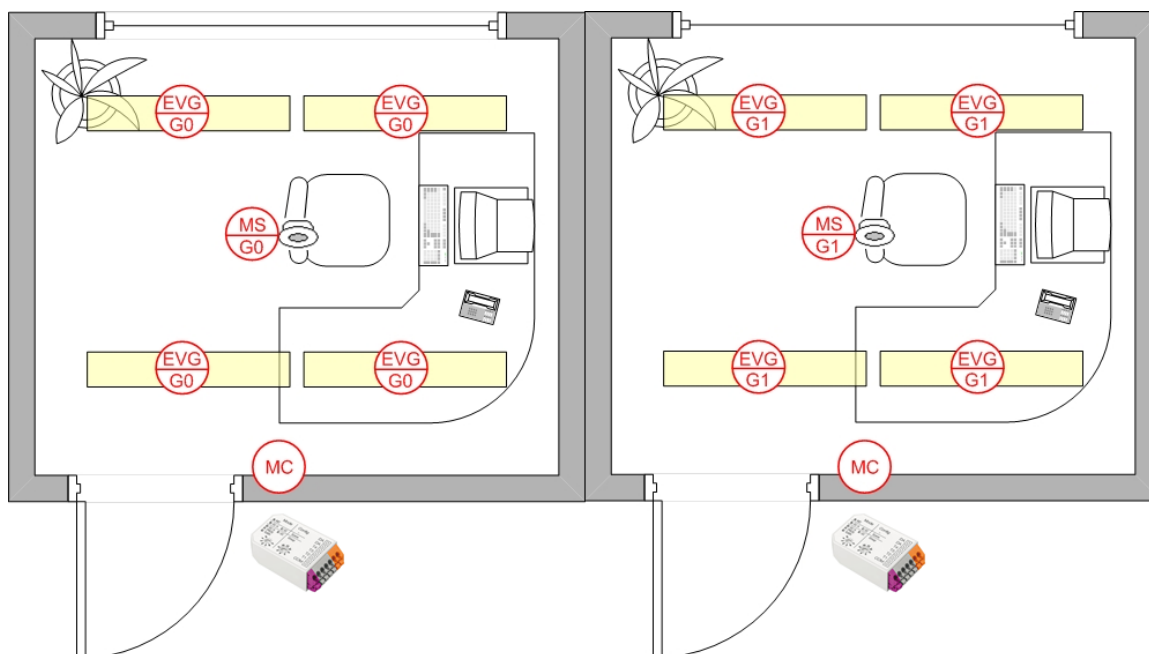

DALI MSensoren

Table: Grouping/configuration

	Room A	Room B
MSensor	Group 0 (switch position 1) Configuration: Scene 0: Automatic control	Group 1 (switch position 2) Configuration: Scene 1: Automatic control
DALI XC	The DALI XC (MC Mode) is used to switch on light control and to switch off the lighting <ul style="list-style-type: none"> _ Activation of light control with scene recall _ Switch off with OFF Configuration of input 1: Target: Group 0 Function: Momentary-action switch Command X: Recall scene 0 Configuration of input 2: Target: Group 0 Function: Momentary-action switch Command X: OFF	The DALI XC (MC Mode) is used to switch on light control and to switch off the lighting <ul style="list-style-type: none"> _ Activation of light control with scene recall _ Switch off with OFF Configuration of input 1: Target: Group 1 Function: Momentary-action switch Command X: Recall scene 1 Configuration of input 2: Target: Group 1 Function: Momentary-action switch Command X: OFF

3.5.5. Corridor

Requirements

- _ Switch on and switch off using motion sensor
- _ Ambient light control of illuminance
- _ Corridor and staircase are separately controlled

DALI USB

Figure: Overview of a corridor set-up

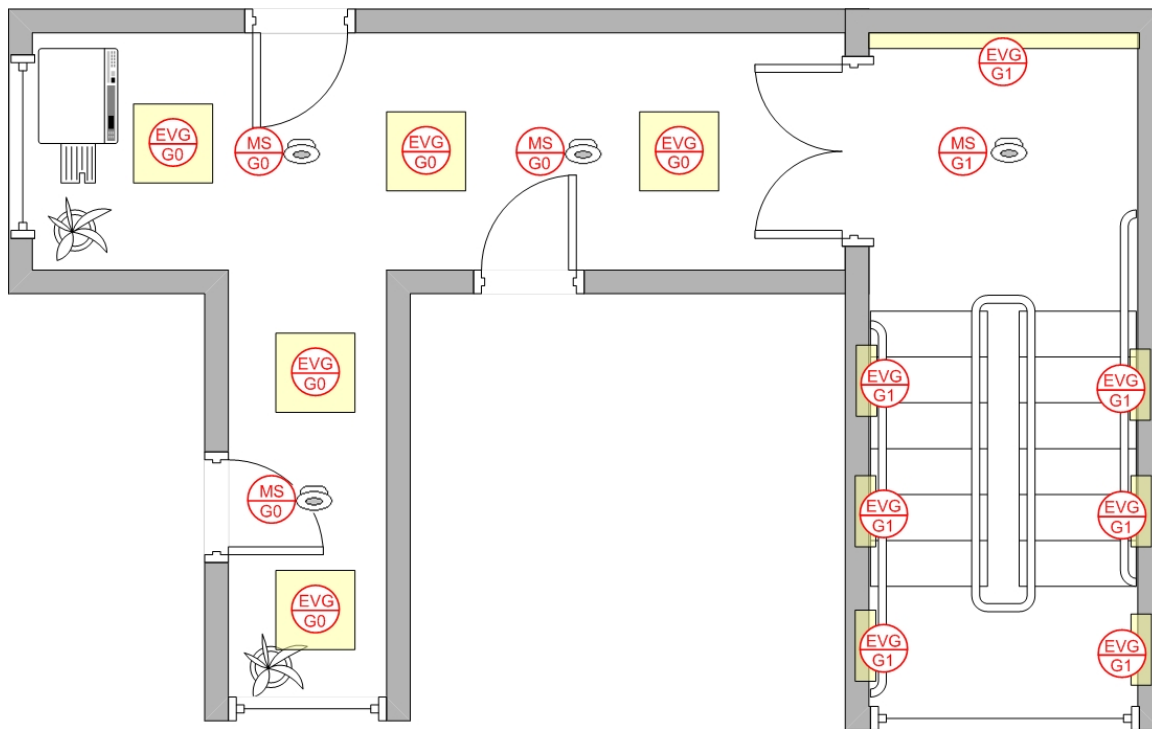

Table: Grouping

	Corridor	Staircase
MSensor	Group 0 (switch position 1)	Group 1 (switch position 2)

i NOTICE

In order to enlarge the presence detection area, several DALI MSensors are installed in the corridor. All these sensors must be assigned to the same luminaire group. If there are multiple DALI MSensors in a group, light control behaves as follows:

- _ the light value is raised until it is no longer less than the setpoint value at any of the sensors.

3.6. DALI USB



The DALI USB is used as an interface between a standard computer (PC) with a USB port and the DALI circuit. It enables complex

DALI USB

DALI installations to be addressed and programmed via configuration tools such as masterCONFIGURATOR.

3.6.1. Connection

The DALI USB is connected directly to the DALI circuit and does not need a separate power supply. It is powered via the DALI circuit (current draw = 6 mA). It can be connected to the DALI circuit with either polarity.

Designing a DALI application

This section is intended to simplify the planning and configuration of DALI installations. Using examples from the Application Guide it discusses the typical requirements of a DALI system and the special features of Tridonic products. The following two aspects deserve special attention when designing a DALI application.

- _ The conceptual aspect: What characteristics must the application have? Should there be daylight-dependent control? Are special lighting scenes or colour applications required? ...
- _ The technical aspect: What is possible with DALI? What are the limitations of DALI and how do these affect the application? ...

In most cases, the prime consideration will be the conceptual aspect. What are the characteristics of the lighting application and what requirements and criteria should they meet? You will then consider the technical aspect and attempt to find the right products to meet these criteria.

The technical aspect of the DALI installation is closely associated with the planning process.

The key to a successful DALI installation starts with the installation plan. The installation plan should contain the following points:

- _ The position of all the DALI devices (including the device type and device name)
- _ The grouping of the DALI devices
- _ The DALI short address (optional); in some installations it makes sense to define the address at the planning stage
- _ The wiring of the DALI circuit including the junction boxes (if there are multiple DALI circuits it is best to colour code them)
- _ The cable lengths for each DALI circuit

4.1. Conventional wiring or DALI

If a requirement profile calls for flexible lighting control in which the assignment of the luminaires and control gear can be changed this must be defined in every detail before the installation phase. For conventional lighting management (without DALI) planners have to take into account all the possible lighting control options before work actually commences. Conventional planning would provide for multiple control lines per room section to cover all the possible options.

With DALI all the lighting control options remain open even after the installation is complete and changes are needed to a particular control variant (planning security). There are no additional costs for multiple control lines or rewiring control lines. The decision to opt for DALI or a conventional control system depends on the functionality required and the flexibility with which the lighting system is to be controlled.

4.2. Design considerations

A number of points deserve special attention when designing a DALI application.

- _ Maximum of 64 DALI devices per DALI circuit
- _ Maximum of 16 DALI groups per DALI circuit
- _ Maximum of 16 DALI scenes per DALI circuit
- _ The current on the DALI circuit must not exceed the maximum current of the power supply (DALI PS1 = 200 mA or DALI PS2 = 240 mA).
- _ The maximum cable length depends on the maximum permitted voltage drop along the DALI cable; this is defined as 2 V max. This corresponds to a maximum cable length of 300 m for a line cross-section of 1.5 mm²; contact resistance must also be taken into account. A voltage drop of 2 V must not be exceeded.

Designing a DALI application

- _ The recommended minimum cable cross-section is 1.5 mm²

4.2.1. Current draw of the DALI circuit

Each device in the DALI circuit consumes current via the DALI circuit. The total current draw on the DALI circuit must not exceed the maximum current of the DALI power supply.

To determine the current draw of a DALI circuit both the current draw of the DALI devices and the current draw of the DALI controllers must be taken into consideration. The current draw of a DALI device is defined in the DALI standard as 2 mA. The current draw of the individual DALI controllers (comfortDIM devices) is shown in the relevant data sheets.

It is important that the current draw of the DALI circuit does not exceed the maximum current of the power supply. In the case of DALI PS1 this is 200 mA, in the case of DALI PS2 this is 240 mA.

Example: DALI circuit with 24 dimmable LED Driver (LCA), 6 DALI XC

Current draw of the individual DALI components (from the data sheet):

- _ Dimmable LED Driver / ballasts = 2 mA
- _ Pushbutton interface (DALI XC) = 6 mA
- _ Sensors (DALI MSensor) = 6 mA

Total current = Summ Current draw of DALI devices + Summ Current draw of DALI controllers

Total current = 24 x ballasts + 6 x DALI XC

Total current = 24 x 2 mA + 6 x 6 mA = 84 mA

4.2.2. Maximum cable length

The maximum cable length depends on the maximum permitted voltage drop along the DALI cable; this is defined as 2 V max. Typically, this requirement is safely met for a cable length of 300 m and a cable cross-section of 1.5 mm². Additional voltage drops at terminal points must be taken into consideration. For cross-sections smaller than 1.5 mm² the maximum cable length is reduced accordingly.

Designing a DALI application

Calculating the voltage drop

The formula for calculating the voltage drop is as follows:

$$U_V = \frac{2 \cdot l \cdot I}{\gamma \cdot S}$$

U_V	Voltage drop in V
I	Current in A (0.25 A)
S	Cross section in mm ²
l	Cable length in m
γ	Electrical conductivity in m / (Ohm mm ²), for copper cable: 56 m / (Ohm mm ²)

i NOTICE

The maximum current of 250 mA must be used for calculating the voltage drop.

Example: DALI circuit with a cable length of 300 m and a cable cross-section of 1.5 mm²

$$U_V = \frac{2 \cdot l \cdot I}{\gamma \cdot S} = \frac{2 \cdot 300 \text{ m} \cdot 0.25 \text{ A}}{56 \cdot 1.5 \text{ mm}^2} = 1.786 \text{ V}$$

Exact result:

This example shows that:

- _ for a cable length of 300 m the voltage drop along the cable is 1.786 V
- _ a further voltage drop of 0.214 V is available for terminal points (contact resistance)

Rule of thumb:

As it is somewhat tricky to calculate the cable length based on the voltage drop the rule of thumb is as follows:

- _ If a cross-section of 1.5 mm² is used, the maximum cable length is 300 m.
- _ If a smaller cross-section is used the possible cable length is reduced accordingly.

Wire length	Cross-section
< 100 Meter	0.5 mm ²
100-150 Meter	0.75 mm ²
> 150 Meter	1.5 mm ²

i NOTICE

Tridonic recommends always using a cable cross-section of 1.5 mm² for DALI control lines.

Designing a DALI application

4.2.3. Wiring

The following points must be considered:

Figure: Typical texture of used wires



- _ DALI systems are installed using conventional wiring material for line voltage.
- _ Two wires are needed for the DALI control circuit.
- _ The line voltage and bus line may be routed in the same cable. This corresponds to a 5-core cable (L, N, PE, DA, DA)

NOTICE

According to DIN VDE 0100/T520/Part 6, main circuits and associated auxiliary circuits may be laid together even if the auxiliary circuits carry a lower voltage than the main circuits. Make sure to use cable designed to take the maximum operating voltage.

Figure: Different polarity of DALI lines



- _ There is no need to worry about the polarity of the DALI line.
- _ The DALI signal is not SELV. The installation instructions for low voltage therefore apply
- _ There are no special network topology requirements (star and mixed networking are permitted). No ring, fully connected and mesh network!

Designing a DALI application

Different DALI topologies

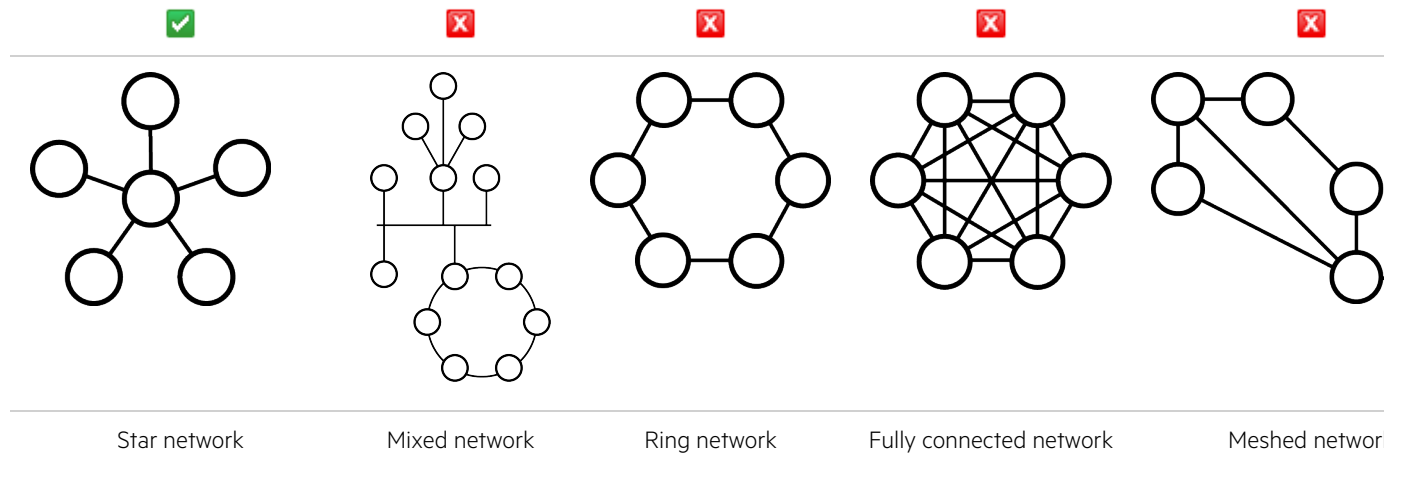
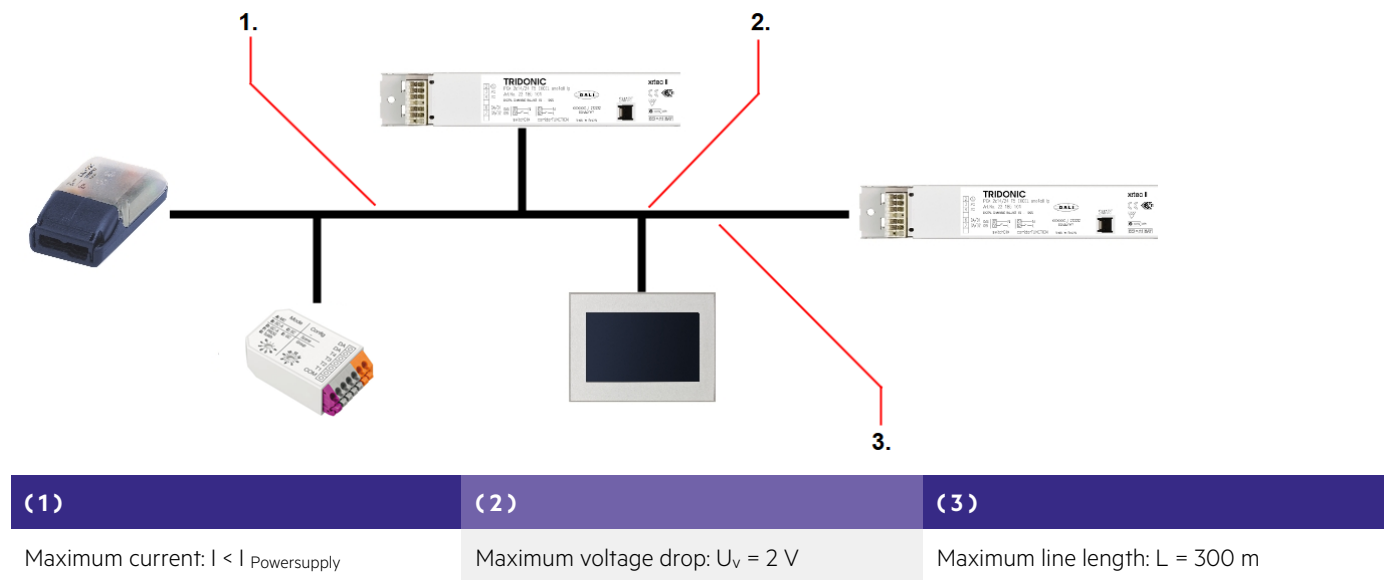

Figure: Maximum values of DALI lines



The maximum length of the DALI line is 300 m (for a cable cross-section of 1.5 mm²). For smaller cross-sections the length is reduced accordingly.

The voltage drop along the DALI control line must not exceed 2 V.

Designing a DALI application

4.3. Sample applications

4.3.1. Conference room



Application

Conference room for about 10 people

Requirement

The lighting in the room consists of 6 linear LED luminaires and 2 LED downlights. The requirements for control are as follows:

- _ The luminaire should be switched and controlled at either of two control points.
- _ There should be a section of different lighting scenarios (e.g. presentation)
- _ The luminaires must be capable of being dimmed

Solution with DALI XC in GC and SC Mode

The room is divided into two groups, one for the LED downlights and the other for the linear LED luminaires. There are two switching points available.

One by the door for switching the lighting on and off. This is implemented with a DALI XC SC mode with the scenes “Lighting on” and “Lighting off”. The second by the window is implemented with a DALI XC in SC mode and a DALI XC in GC mode and enables any of four scenes to be retrieved and both luminaire groups to be individually dimmed.

Alternative is to use DALI XC in MC mode.

Designing a DALI application

Figure: Installation for conference room without wiring

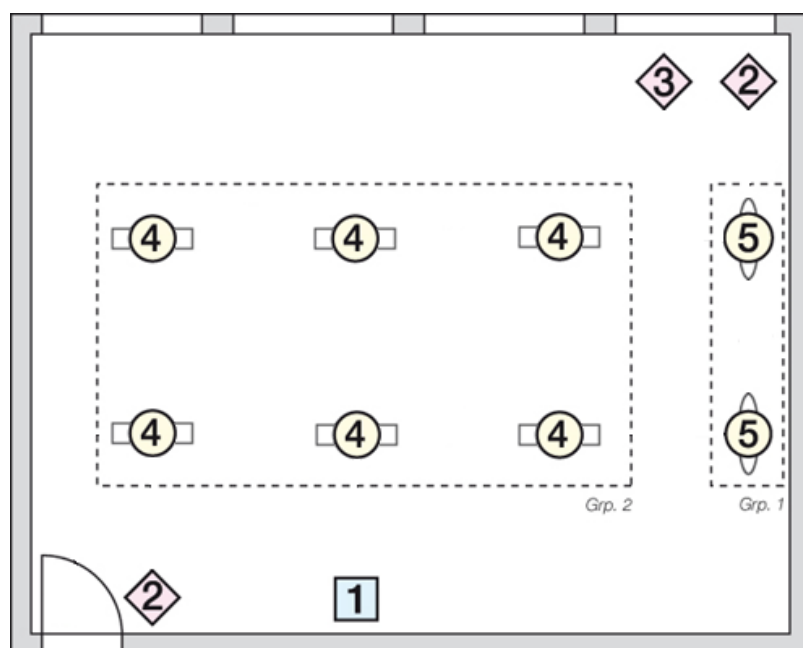

Table: Parts list

Pos.	Qty		Article name
1	1	DALI power supply	DALI PS1
2	2	DALI XC in SC mode (scene controller)	DALI XC
3	1	DALI XC in GC mode (group controller)	DALI XC
4	6	DALI LED control gear for linear luminaire	LCAI one4all
5	2	DALI LED control gear for LED downlights	LCAI one4all

Designing a DALI application

Table: DALI checklist

DALI condition	Planned/present	
Maximum of 64 DALI ECGs	8 DALI devices	✓
Maximum of 16 groups	2 groups	✓
Maximum of 16 scenes	4 scenes	✓
DALI circuit current < Rated power supply current	34 mA	✓
Line length < 300 m (for 1.5mm ²)	approx. 20m	✓
5 wires to each luminaire	5 x 1.5mm ²	✓
DALI LED control gear in luminaire	Tridonic LCAI one4all	✓

Figure: Installation for Conference room with wiring

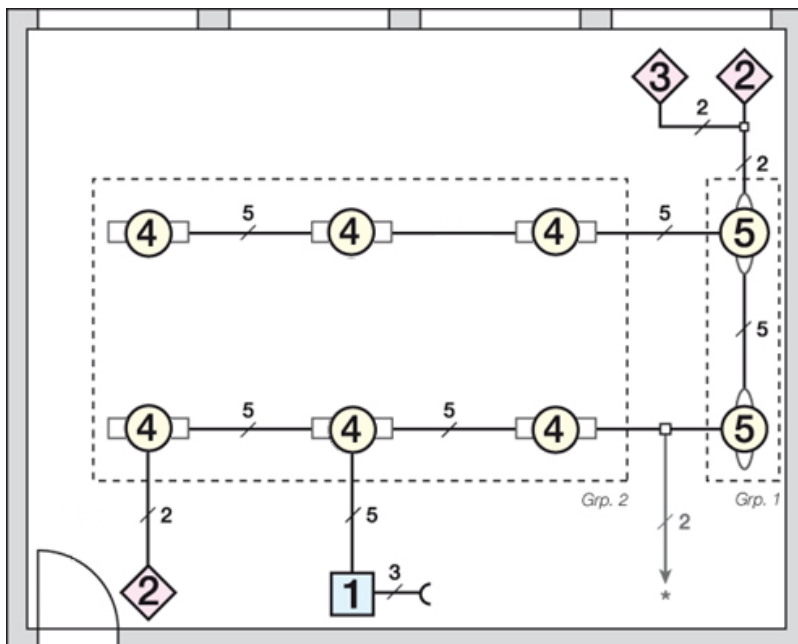

Grouping

The luminaires can be grouped in either of two ways. With the DALI XC in GC mode itself or with the masterCONFIGURATOR configuration software (see [Reference list](#), p. 82).

Designing a DALI application

Table: Grouping

	Conference room
Downlights	Group 1
Linear luminaires	Group 2
DALI XC	Switch position = 1 (Group 1+2): Group 1 => Switch for downlights
GC mode	Group 2 => Switch for linear luminaires

Scene assignment

Scenes are called up from two locations. Directly next to the door there is a double switch for switching the light on and off. The control point next to the screen can also be used to switch the light on and off. In addition, two further user-defined scenes (e.g. presentation) can be called up.

Here too the scenes can be set up in two ways, with the DALI XC in SC mode or with the masterCONFIGURATOR configuration software (see [Reference list](#), p. 82).

Table: Scene assignment

	Control point near door	Control point near screen
DALI XC SC mode	Switch position = 1 (Scenes 1-4): Scene 1 => Light off Scene 2 => Light 100% Scenes 3 and 4 not wired	Switch position = 1 (Scenes 1-4): Scene 1 => Light off Scene 2 => Light 100% Scene 3 => Presentation Scene 4 => Meeting

Designing a DALI application

4.3.2. Open-plan office



Application

Office with 6 workstations plus cabinets.
Each desk has 2 workstations.

Requirement

The lighting consists of 3 rows of luminaires, 2 rows above the workstations and 1 in the walkway and cabinet area.
The requirements for control are as follows:

- _ On/off switching via motion sensors
- _ Daylight-dependent control of illuminance
- _ Manual control via DALI TOUCHPANEL

Figure: Installation for Open-plan office without wiring

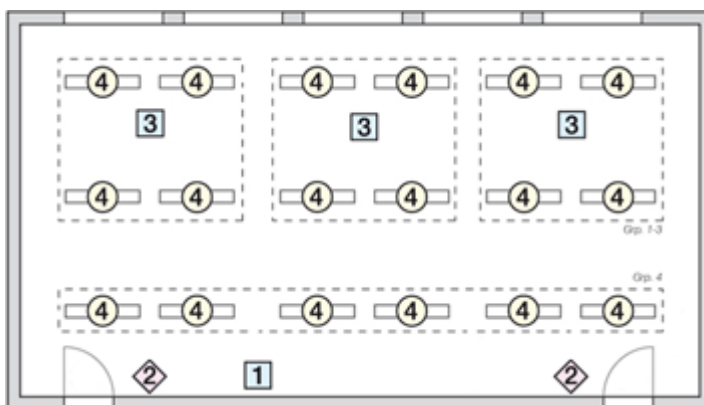

Solution with DALI MSensor 02

The room is divided into 4 groups, 3 for the workstation islands and 1 for walkway and cabinet area lighting. The 3 groups for the workstation islands are each controlled with a DALI MSensor. The fourth group is controlled with 3 DALI MSensor (increased presence detection area).

Each workstation island and the walkway lighting is independently controlled (presence detection and ambient light control).

Designing a DALI application

Table: Parts list

Pos.	Qty		Article name
1	1	DALI power supply	DALI PS1 / DALI PS2
2	2	DALI touchpanel	DALI TOUCHPANEL 02
3	3	DALI MSensor	DALI MSensor 02 (5DPI 41 rc)
4	18	DALI LED control gear for linear luminaires	LCAI one4all

Table: DALI checklist

DALI condition	Planned / present	
Maximum of 64 DALI ECGs	18 DALI devices	✓
Maximum of 16 groups	4 groups	✓
Maximum of 16 scenes		✓
DALI circuit current < Rated power supply current	66 mA	✓
Line length < 300 m (for 1.5mm ²)	approx. 50 m	✓
5 wires to each luminaire	5 x 1.5mm ²	✓
DALI LED control gear in luminaire	LCAI one4all	✓

Figure: Installation for open-plan office with wiring

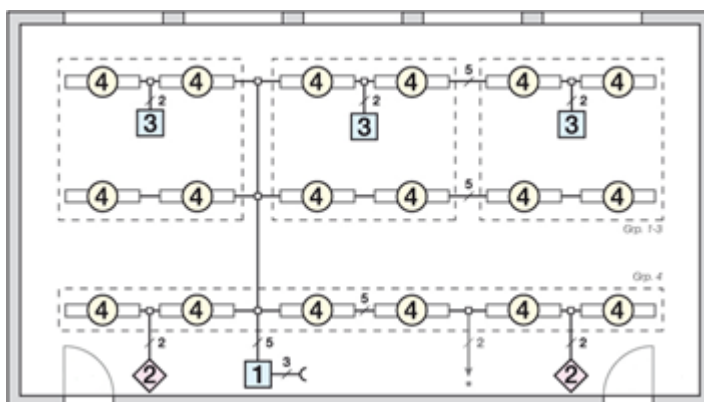

Grouping

The luminaires can be grouped with the masterCONFIGURATOR software (see [Reference list](#), p. 82).

Designing a DALI application

Table: Grouping

	Workstation island 1	Workstation island 2	Workstation island 3	Walkway / cabinet lighting
Luminaires	Group 1	Group 2	Group 3	Group 4
DALI MSensor 02	Rotary switch position = 1 Luminaire group 1	Rotary switch position = 2 Luminaire group 2	Rotary switch position = 3 Luminaire group 3	

Start-up

There are various ways of putting a DALI application into operation. Some of the comfortDIM products have the option of putting small (single-room) applications directly into operation. One of these products is the DALI XC in GC mode. With the DALI x/e-touchPANEL 02 it is easy to set up the parameters even for medium-size applications.

For information on how these products can be used to set the parameters of a DALI circuit, please refer to Section 3 of this manual or to the operating instructions for the relevant product.

For large DALI applications the simplest way to set up the DALI circuit is to use the masterCONFIGURATOR software. These two programs can be downloaded free of charge from the homepage at www.tridonic.com. In addition the DALI USB is needed for connecting the DALI circuit to a computer.

5.1. Before you get started

Before starting the set-up process, make sure the DALI Drivers are connected to the power supply and to the DALI circuit. If there is more than one DALI circuit you should also check that the LED control gears are connected to the right DALI circuit.

- _ Are all the LED control gears connected to the power supply?
Check the power connection by switching on the circuit breaker. All the DALI Drivers should go to the “Power-On-Level” (factory setting 100 %)

- _ Are all the DALI Drivers connected to the (right) DALI circuit?
There are various ways of testing the circuit. You can test the installation with a DALI XC in GC mode set to Broadcast. The XC is used here to activate the DALI circuit and check whether all the devices in the DALI circuit switch on.

If masterCONFIGURATOR is used for setting up the DALI installation there is also the option of checking whether all the DALI Drivers are connected to the right DALI circuit.

Start-up

5.2. Sample set-up for a conference room

This section uses the example of the conference room from Chapter 4 to show how a DALI application can be put into operation with the aid of masterCONFIGURATOR in six easy steps.

The conference room contains 8 DALI luminaires, two DALI XC in SC mode units, one DALI XC in GC mode unit and one DALI Power Supply. The rotary switches on the DALI XC in SX and GC mode have already been set to the correct position during installation. The luminaires are connected to the power supply and to the DALI circuit.

5.2.1. Solution with DALI XC in GC mode and SC mode

The room is divided into two groups, one for the LED downlights and the other for the linear LED luminaires. There are two switching points available.

One by the door for switching the lighting on and off. This is implemented with a DALI XC in SC mode with the scenes “Lighting on” and “Lighting off”. The second by the window is implemented with a DALI XC in SC mode and a DALI XC in GC mode and enables any of four scenes to be retrieved and both luminaire groups to be individually dimmed.

Figure: Installation for conference room without wiring

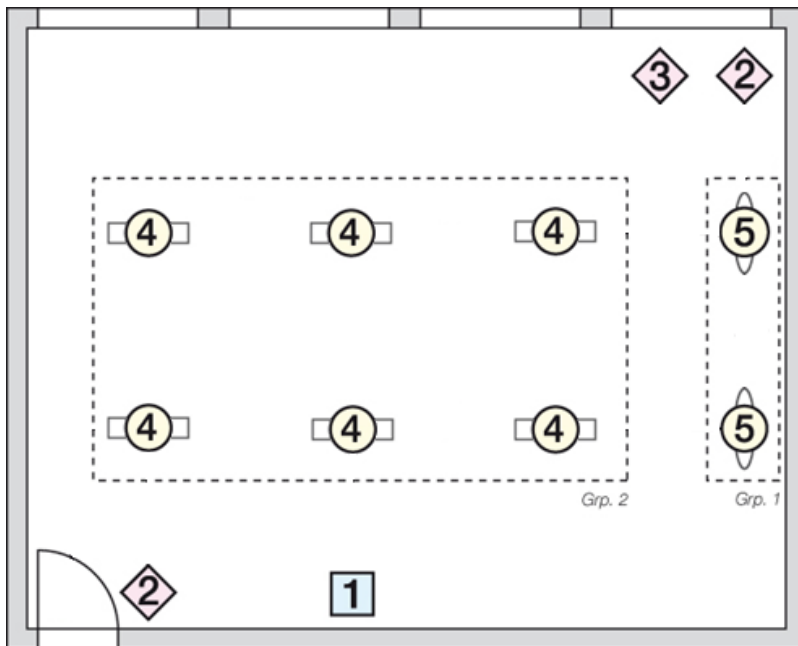

Start-up

Table: Parts list

Pos.	Qty		Article name
1	1	DALI power supply	DALI PS1 / DALI PS2
2	2	DALI XC in SC mode (scene controller)	DALI XC
3	1	DALI XC in GC mode (group controller)	DALI XC
4	6	DALI LED control gear for linear luminaire	LCAI one4all
5	2	DALI LED control gear for downlights	LCAI one4all

Table: Grouping

	Conference room
Downlights	Group 1
Linear luminaires	Group 2
DALI XC	Switch position = 1 (Group 1+2): Group 1 => Switch for downlights
GC mode	Group 2 => Switch for linear luminaires

Scene assignment

Scenes are called up from two locations. Directly next to the door there is a double switch for switching the light on and off. The control point next to the screen can also be used to switch the light on and off. In addition, two further user-defined scenes (e.g. presentation) can be called up.

	Control point near door	Control point near screen
DALI XC SC Mode	Switch position = 1 (Scenes 1-4): Scene 1 => Light off Scene 2 => Light 100 % Scenes 3 and 4 not wired	Switch position = 1 (Scenes 1-4): Scene 1 => Light off Scene 2 => Light 100 % Scene 3 => Presentation Scene 4 => Meeting

Start-up

5.2.2. Installation

The DALI circuit is installed using standard installation material for mains voltage. The mains voltage and DALI line may be routed in the same cable. There is therefore no need for a separate bus line, but one can be used if required.

Figure: Wiring diagram

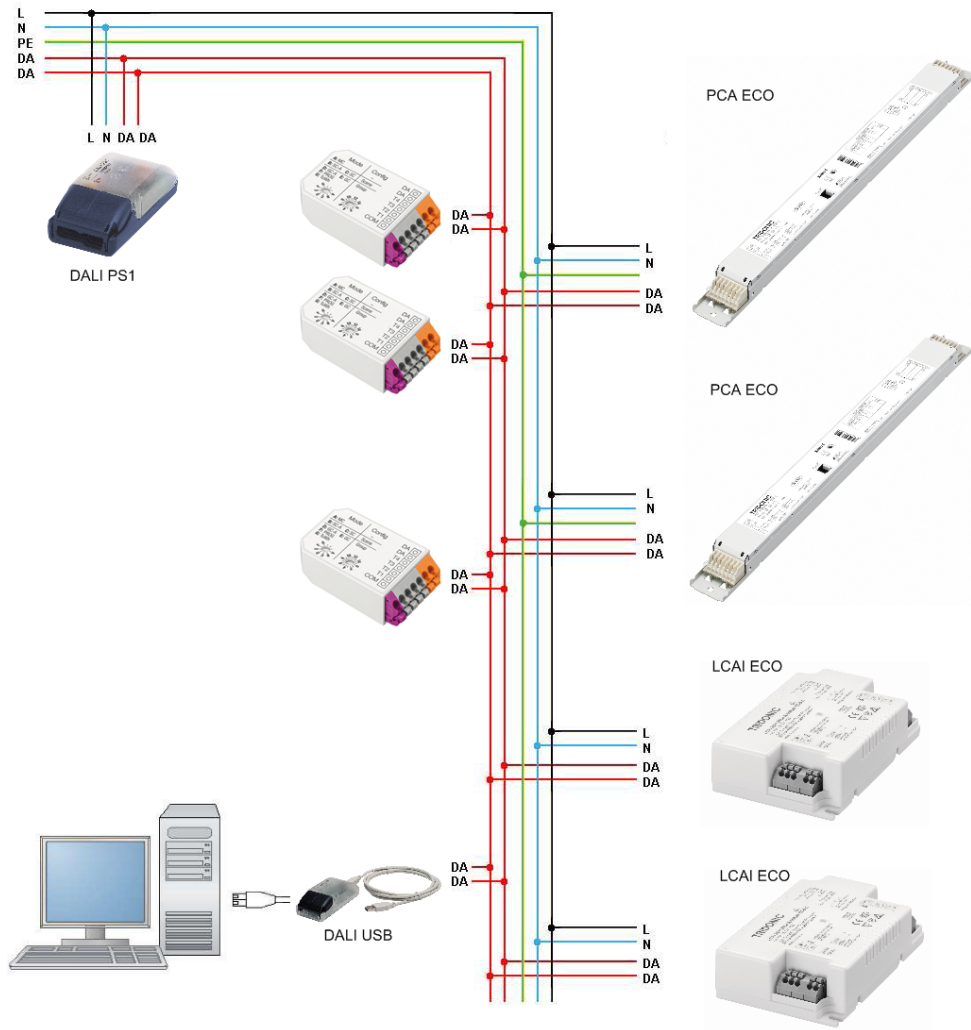

ALI USB is needed only for set-up with masterCONFIGURATOR and can then be removed.

Installing and connecting DALI XC

Standard switches can be used for installing DALI XC. DALI XC is installed directly in a flush-mounted box, underneath or behind the light switch. Power is supplied to DALI XC via the bus line. It must not be connected to the ac power supply. The switches are connected directly to DALI XC (floating make contacts).

- _ Turn rotary switch to used mode position

Start-up

Figure: Up and down switch connections (left) and single switch connection (right)

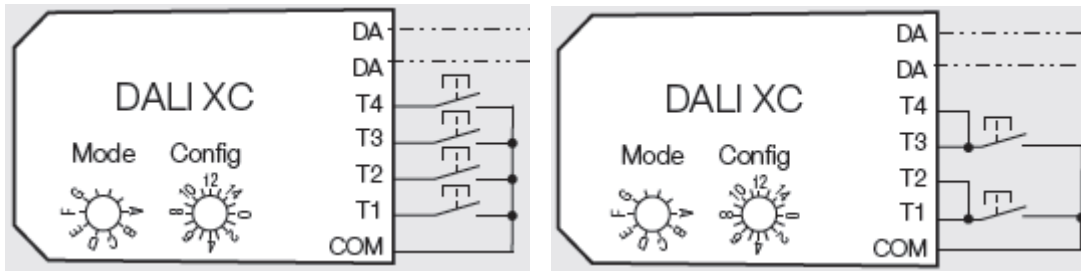
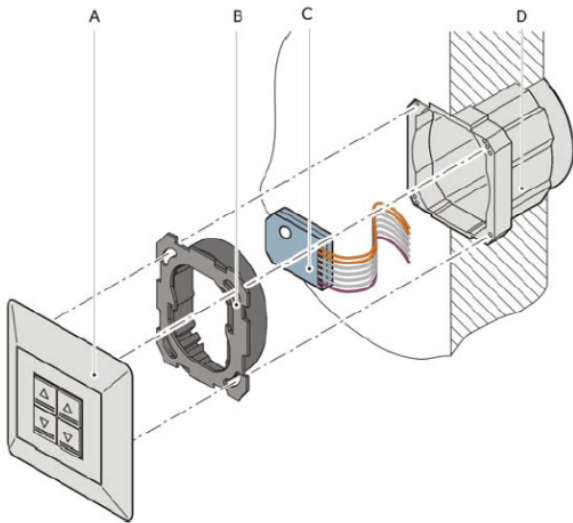

Figure: Installing a DALI XC (A, B switch module; C DALI XC; D flush-mounted box)



Start-up

5.2.3. Setting up without software

An application with two DALI XC in SC mode and one DALI XC in GC mode enables the installation to be set up without software.

Step 1: Enter programming mode on the DALI XC in GC mode (new installation)

DALI XC in GC mode switches to programming mode and addresses the DALI Drivers.

After the addressing cycle the DALI Driver with the first address is switched to 100 %, and all the others to the "Min. Level" parameter

Step 2: Grouping the luminaires with the aid of DALI XC in GC mode

Select the first luminaire => assign the right group to the selected luminaire

Select the next luminaire => assign the right group to the selected luminaire

This process is repeated until all eight luminaires have been assigned to the 2 groups.

Step 3: Exiting the DALI XC in GC programming mode

Step 4: Saving the scene values

Fade the two DALI groups to the required brightness value of scene 1 and save the value by pressing scene button 1 for 10 seconds.

Repeat this procedure for the other scenes.

When you have completed these four steps the set-up process is complete and the system is ready for use.

What are the limits of manual set-up?

With manual set-up it is possible to put small applications into operation. As the systems increase in size, so the set-up process becomes more and more complex. It is therefore best to use masterCONFIGURATOR (see [Reference list](#), p. 82) to put these systems into operation.

Manual set-up is not as flexible as set-up using a software tool. For example, a scene can only be set to the same value for an entire group (e.g. Group 1: 80 % and Group 2: 20 %). It is not possible to set different scene values within a group. Systems with DALI control modules such as DALI MC and DALI TOUCHPANEL can only be set up with the aid of a software tool.

Start-up

5.2.4. Setting up with masterCONFIGURATOR

The masterCONFIGURATOR enables the wiring of the DALI circuit to be tested, the devices to be addressed and the group and scene settings to be completed, all in 5 easy steps. The masterCONFIGURATOR has its own separate documentation (see [Reference list](#), p. 82).

Preparation

Before you can start setting up with masterCONFIGURATOR the DALI circuit must be linked to the computer via a DALI USB.

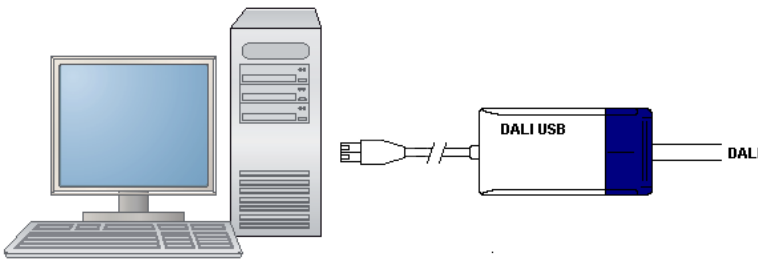

Open the masterCONFIGURATOR to view the main window of the masterCONFIGURATOR. You can access all the parameterisation and configuration options from this program window. Some options open further windows.

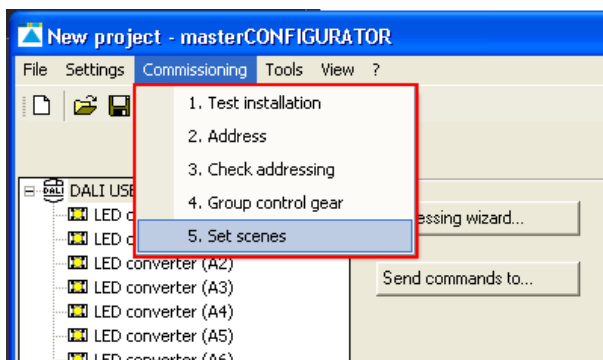

Step 1: Testing the wiring

This step checks that the wiring is correct for the installation.

After the test has been started the DALI commands “Recall min. Level” and “Recall max. Level” are sent alternately to all the devices in the DALI circuit, causing the connected devices to flash.

This test determines whether communication is working properly in the DALI circuit and whether all the devices in the DALI circuit are connected.

Start-up

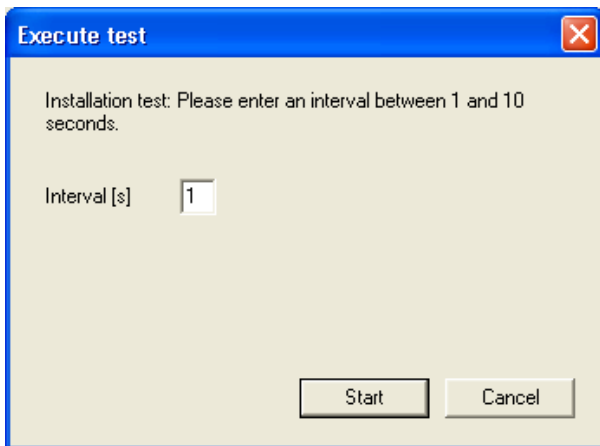

- _ Select "Start Test"
- >The 8 DALI luminaires start to flash, which means that installation has been successfully completed.
- _ Pressing the button again cancels the test

Step 2: Finding devices

- _ Start the Addressing Wizard

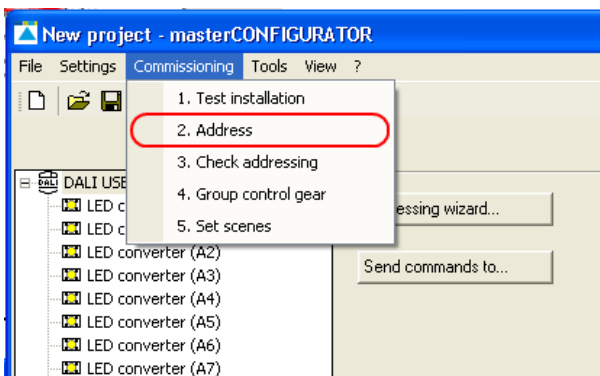

- _ Select "System extension" or "new initialisation"

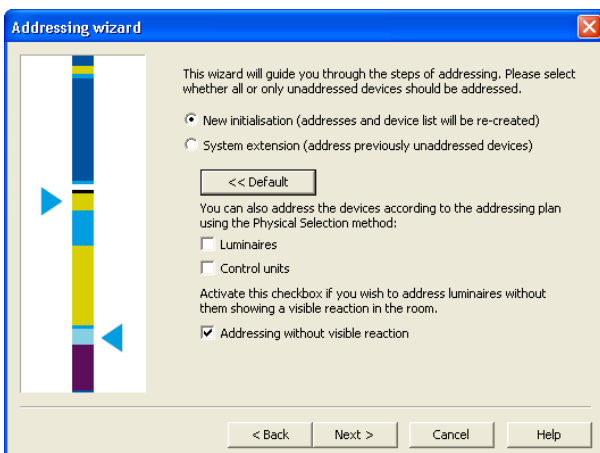

- _ Select "new initialisation"
- _ Press "Next" to start the addressing process

Start-up

Step 3: Testing the addresses

Testing the addresses involves the devices being switched on one after the other with all the other devices switched off. The process is repeated when the last address is reached.

This function can be used to check whether the addresses are assigned as required.

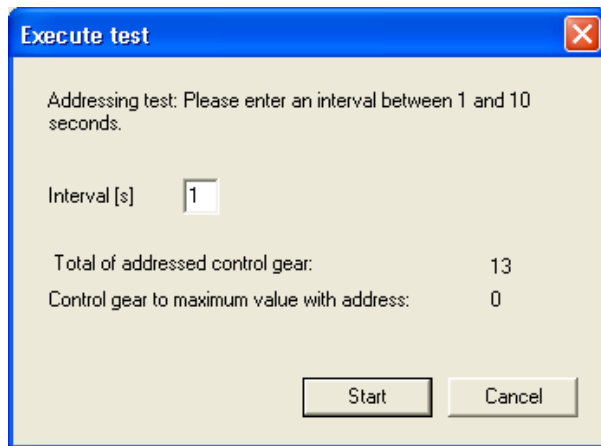

Start-up

Step 4: Grouping the devices

In this step the various ballasts are assigned to the DALI groups.

- _ Chose and highlight relevant device
- _ Click "Add >>" to add device to the group
- _ If necessary: Click "<< Remove" to remove device from group again

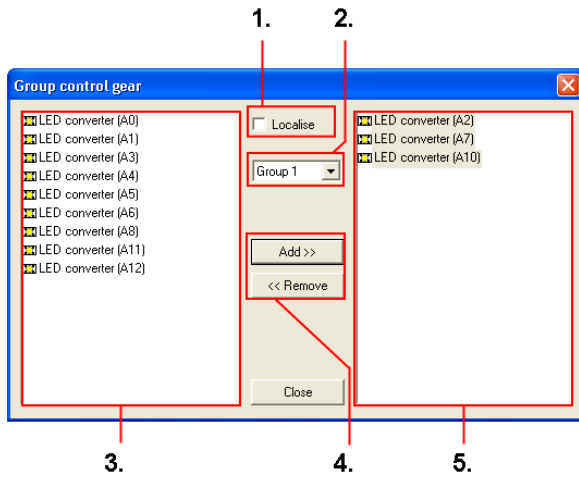

(1)	(2)	(3)	(4)	(5)
Show selection: The highlighted luminaire is switched to 100%, the others to the minimum fade value	Group selection: Selection of the DALI group	Device container: Available DALI devices	Add/remove: Adds the highlighted device to the group or removes it.	Group container: Overview of the devices assigned to the group

- _ We assign the two downlights to Group 1 and the linear luminaires to Group 2
- _ Ticking the "Show selection" checkbox causes the luminaire highlighted in masterCONFIGURATOR to light up and enables the luminaires to be easily assigned to the DALI groups
 -> During addressing the luminaires received the DALI addresses entered in the circles for example (random addressing)

Start-up

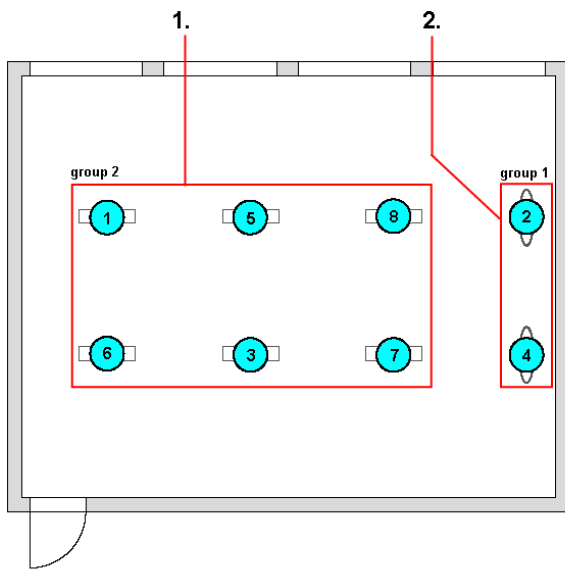

(1)

Linear Luminaires:

Drag luminaires with addresses 1, 3, 5, 6, 7 and 8 to Group 2

(2)

Downlights:

Drag the luminaires with addresses 2 and 4 to Group 1

Step 5: Assigning scenes



In the "Assign scenes" step dimming values for the various DALI groups can be assigned to the 16 DALI scenes of the DALI circuit. Clicking on the "Assign scene" button transfers the values to the relevant ballasts.

_ Setting parameters:

- Scene 1: Group 1 = 0 %, Group 2 = 0 %
- Scene 2: Group 1 = 100 %, Group 2 = 100 %
- Scene 3: Group 1 = 50 %, Group 2 = 20 %
- Scene 4: Group 1 = 10 %, Group 2 = 10 %

_ and then press "Assign scenes"

Start-up

This concludes the process of setting parameters for the application. Detailed information about the masterCONFIGURATOR can be found in the manual of the tool (see [Reference list](#), p. 82).

Figure: Example scenes



Scene 2 (100 %, 100 %)



Scene 3 (50%, 20%)

Maintenance and troubleshooting

6.1. Failure of a DALI Driver

DALI is based to a large extent on distributed intelligence, which means that the addresses and parameters such as group assignment and scene values are stored in the DALI Drivers. If a DALI Driver fails, these parameters must be reset in the replacement DALI Driver. DALI Drivers straight from the factory are not programmed with any addresses, group assignments or scene values.

The simplest option is to use masterCONFIGURATOR:

1. Replace the faulty DALI Driver with a new DALI Driver
2. Address the DALI Driver with the function “System expansion” or “Only address new (not yet addressed) devices”. The lowest free DALI short address is automatically assigned to the new DALI Driver. Since there is an address missing in the circuit (that of the faulty DALI Driver), it is automatically given the address of the old DALI Driver. If several devices are faulty their replacements are randomly assigned the free addresses.
3. Reprogram the group assignments and scene values.

6.2. Exceeding the maximum cable length or short-circuits in the DALI circuit

There are certain points that deserve special attention when designing a DALI application. These include the limit on the current in the DALI circuit and the limit on the cable length due to the maximum permissible voltage drop on the DALI line.

What happens if these limits are exceeded?

The system does not then behave as it should and some strange phenomena occur.

For example:

- _ DALI devices react to broadcast commands but cannot be found during addressing
- _ Not all the DALI devices connected to the DALI circuit are found.
- _ Different numbers of devices are found at successive addressing processes.
- _ The devices do not react reliably to DALI commands.

The most common problems in a DALI installation result from the maximum voltage drop in the circuit being exceeded and from a short-circuit somewhere on the DALI line. But how is the voltage drop in the DALI circuit measured?

Maintenance and troubleshooting

6.2.1. Measuring the voltage drop in a DALI circuit

Proceed as follows:

- _ Check that all the DALI devices are functioning properly.
- _ Make sure there is no communication on the DALI line.
- _ Measure the voltage at the DALI power supply.
 - _ The value must be between 11.5 V and 22.5 V; a typical value is 16 V.
 - _ A much lower value may indicate a short-circuit.
- _ Measure the voltage at the DALI device furthest from the DALI power supply.
 - _ The value must be between 9.5 V and 20.5 V.
 - _ A much lower value indicates that there is a short-circuit somewhere.
- _ Create a short-circuit between DA and DA at the DALI device furthest from the DALI power supply.
- _ Measure the voltage at the DALI power supply.
 - _ The value that you measure is the DALI voltage drop.
 - _ This value must not be higher than 2 V.
 - _ If it is higher than 2 V, check whether any of the following have occurred:
 - _ The DALI line is too long (more than 300 m at 1.5 mm²)
 - _ The cross-section is too small
 - _ High contact resistance
 - _ The value must be brought down below 2 V.
- _ Remove the short-circuit between DA and DA on the DALI device furthest from the DALI power supply.

6.2.2. Possible solution: DALI Repeater

If the voltage drop is greater than 2 V, a possible solution is to use a DALI Repeater

A DALI Repeater is not the right answer in every situation; its use depends to a large extent on the wiring. First, the wiring of the DALI circuit must be checked. This solution should only be used if no other solution is practical. Above all, you must find out why the system has not been working properly up to now. Make sure that you will not be faced with the same problem again.

A DALI Repeater can help

- _ If the DALI cable is longer than 300 m with a cross-section of 1.5 mm².
- _ If the cross-section is too small.

CAUTION

Please read the data sheet carefully before using a DALI repeater.

Maintenance and troubleshooting

Example: DALI circuit with a voltage drop greater than 2 V

In this example the DALI voltage drop is well above the limit of 2 V. The DALI line is too long. It is 470 m instead of the permitted 300 m.

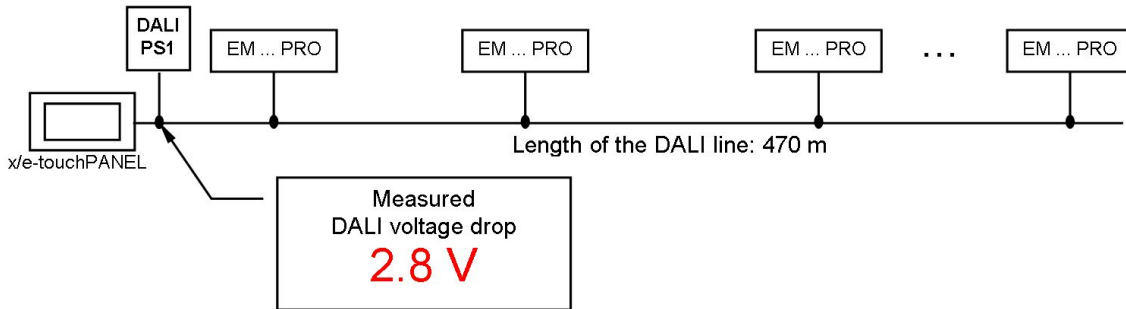

Example: Two DALI circuits with a voltage drop less than 2 V

The DALI circuit is divided into two when a DALI repeater is used. The two circuits are now both below the maximum permitted DALI voltage drop of 2 V. The voltage drop must be measured in both circuits (at the two DALI power supplies). Two additional components are required – a DALI-PS1 or DALI-PS2 and a DALI repeater.

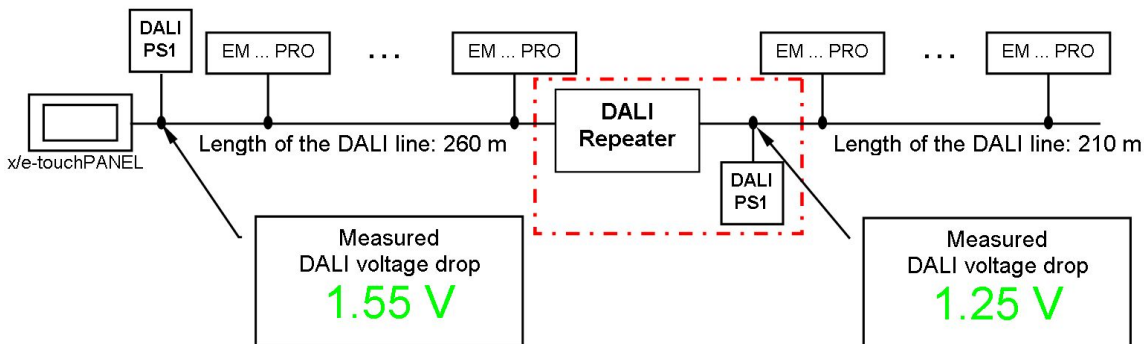

Maintenance and troubleshooting

6.3. Double addressing problem at set-up

In rare cases more than one DALI device may have the same short address. If a DALI command is sent to such a short address the devices will react simultaneously. It will not be possible to address just one device; all the devices with the same short address will always react together. It will not be possible to get the correct response from these devices.

What can cause double addressing problems?

- _ The problem may occur very rarely as a result of the normal addressing algorithm.
- _ DALI lines that have already been addressed are connected to one another.
- _ A faulty DALI device is replaced with a device that has already been addressed.

After addressing, the number of addressed devices is shown. This number (DALI short addresses) must be the same as the number of connected devices. If there are fewer addresses than connected devices the DALI circuit must be re-addressed.

masterCONFIGURATOR provides a way of identifying any double addressing problems. It shows if a device does not send back a clear response. Unknown devices or false device information also indicate double addressing or a faulty device.

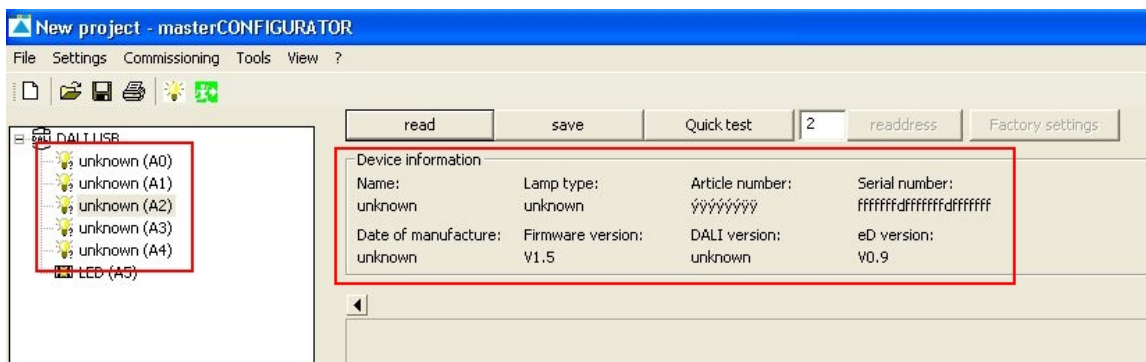

If double addressing has occurred the DALI circuit must be readdressed (select the option “new installation”). This action deletes all existing addressed and reassigns them.

Annex

7.1. Technical features of a DALI circuit

- _ Maximum no. of DALI units: 64
- _ Maximum no. of DALI groups: 16
- _ Maximum no. of DALI scenes: 16
- _ DALI voltage: 9.5 V – 22.5 V, typically 16 V
- _ DALI system current: Max. 250 mA (depending on the installed DALI power supply)
- _ Data transfer rate: 1200 baud
- _ Maximum cable length: The maximum cable length depends on the maximum permitted voltage drop along the DALI cable; this is defined as 2 V max. This corresponds to a maximum cable length of 300 m for a line cross-section of 1.5 mm².

CAUTION!

When calculating the maximum cable length the contact resistance must also be taken into account.

- _ A voltage drop of 2V must not be exceeded.

Annex

7.2. Important DALI parameters and DALI commands

Table: Important DALI Driver parameters

DALI parameter	Description
Actual Level	Current brightness value of the DALI Driver
Maximum Level	Maximum brightness value – this value cannot be exceeded when fading up
Minimum Level	Minimum brightness value – this value cannot be undershot when fading down
Power ON Level	Brightness value to which the DALI Driver switches when the power supply is switched on.
System Failure Level	Brightness value to which the DALI Driver switches when a fault is detected in the DALI circuit (e.g. interruption or short-circuit on the DALI line)
Fade Time	Time in seconds for fading from the current brightness value to the new brightness value (for DAP commands and scene calls)
Fade Rate	Fade steps per second that are performed in response to an indirect fade command (Up and Down commands)
Scene registers 1-16	These registers are where the brightness values for the individual scenes are stored.
Group register	This register is where the group assignment of the DALI Driver is stored.

Annex

Table: Important DALI commands

DALI command	Description
Light level (DAP)	Recalls the light value specified in the command. (The Fade Time parameter is used as the cross-fade time) DAP 0 means: Switch off the light in the cross-fade time set in the Fade Time parameter
Off	Instantly switches the light off (no fade time)
Up	Increases the light value for 200 ms by the fade steps defined in the Fade Rate parameter. When the light value reaches the value defined in the Maximum Level parameter it remains at this value.
Down	Reduces the light value for 200 ms by the dimming steps defined in the Fade Rate parameter. When the light value reaches the value defined in the Minimum Level parameter it remains at this value.
Step up	Increases the light value by one step
Step down	Reduces the light value by one step
On and Step up	Switches the light to the Minimum Level if the device was already off. If the device is on, the light value is increased by one step.
Step down and off	Reduces the light value by one step. When the device reaches the Minimum Level it is switched off.
Recall MIN Level	Calls up the Minimum Level light value (no cross-fade time)
Recall MAX Level	Calls up the Maximum Level light value (no cross-fade time)
Go to scene X	Calls up lighting scene "X". (The Fade Time parameter is used as the cross-fade time)

Annex

7.3. Current draw of the comfortDIM products in the DALI circuit

Table: comfortDIM current draw

Category	comfortDIM device	DALI current draw
Manual control unit	DALI XC	6 mA
	DALI TOUCHPANEL 02	6 mA
Sensors	DALI MSensor 02 5DPI 41f	6 mA
	DALI MSensor 02 5DPI 41rc	6 mA
	DALI MSensor 02 5DPI 41w	6 mA
	DALI MSensor 02 5DPI 41rs	6 mA
	DALI MSensor 5DPI 14f	6mA
	DALI MSensor 5DPI 14rc	6mA
Sequencers	x/e-touchPANEL 02	2 mA (per DALI circuit)
Relays	DALI RM	12 mA
	DALI RM/S 4x10 A	2 mA
Amplifiers	DALI Repeater	6 mA
PC links	DALI USB	6 mA
DALI Driver		2 mA

Table: Overview DALI power supply

Category	comfortDIM device	DALI rated current
Power supply	DALI PS1	200 mA
	DALI PS2	240 mA
	DALI RS232 Interface PS/S	240 mA

Annex

7.4. DALI MSensor broadcast commands and luminaire group commands

DALI command	Broadcast commands	Luminaire group commands
Light level (DAP)	Light level is called up => Lighting control is temporarily disabled (static operation)	Light level is called up => Lighting control is temporarily disabled (static operation)
OFF	off	off
UP	Can be set using masterCONFIGURATOR Factory setting: Dimming light level => Lighting control is temporarily disabled (static operation)	Can be set using masterCONFIGURATOR Factory setting: Dimming light level => Lighting control is temporarily disabled (static operation)
DOWN		
STEP UP	Dimming light level => Lighting control is temporarily disabled (static operation)	Dimming light level => Lighting control is temporarily disabled (static operation)
STEP DOWN	Dimming light level => Lighting control is temporarily disabled (static operation)	Dimming light level => Lighting control is temporarily disabled (static operation)
ON AND STEP UP	Dimming light level => Lighting control is temporarily disabled (static operation)	Dimming light level => Lighting control is temporarily disabled (static operation)
STEP DOWN AND OFF	Dimming light level => Lighting control is temporarily disabled (static operation)	Dimming light level => Lighting control is temporarily disabled (static operation)
RECALL MIN LEVEL	MIN LEVEL is called up => Lighting control is temporarily disabled (static operation)	MIN LEVEL is called up => Lighting control is temporarily disabled (static operation)
RECALL MAX LEVEL	Can be set using masterCONFIGURATOR Factory setting: MAX LEVEL is called up => Lighting control temporarily disabled (static operation)	Can be set using masterCONFIGURATOR Factory setting: MAX LEVEL is called up => Lighting control temporarily disabled (static operation)

Annex

GO TO SCENE X	<p>Can be set using masterCONFIGURATOR</p> <p>Factory setting: Calling up Scenes 0-14 => Lighting control temporarily disabled (static operation) Calling up Scene 15 => Lighting control is enabled (automatic operation)</p>	<p>Can be set using masterCONFIGURATOR</p> <p>Factory setting: Calling up Scenes 0-14 => Lighting control temporarily disabled (static operation) Calling up Scene 15 => Lighting control is enabled (automatic operation)</p>
---------------	--	--

Reference list

7.5. Reference list

7.5.1. Related documents

- _ DALI - At a glance:
www.tridonic.com/com/en/download/technical/DALI_important_facts_at_a_glance_en.pdf

- _ Comparison between DALI and DALI-2
https://www.tridonic.com/com/en/download/technical/DALI-Comparison-between-DALI-and-DALI-2_en.pdf

- _ Documentation masterCONFIGURATOR:
http://www.tridonic.com/com/en/download/Manual_masterConfigurator_en.pdf

- _ Documentation DALI MSensor 02:
http://www.tridonic.com/com/en/download/technical/DALI_MSensor02_ProductManual_en.pdf

- _ Documentation DALI MSensor 5DPI 14:
<https://www.tridonic.com/com/en/products/dali-msensor-5dpi-14.asp>
https://www.tridonic.com/com/en/download/data_sheets/DALI_MSensor_5DPI_14_en.pdf
https://www.tridonic.com/com/en/download/technical/DALI_MSensor_5DPI_14_ProductManual_en.pdf

- _ Documentation DALI XC:
<https://www.tridonic.com/com/en/products/dali-xc.asp>
https://www.tridonic.com/com/en/download/data_sheets/DALI_XC_en.pdf
https://www.tridonic.com/com/en/download/technical/Manual_DALI_XC_en.pdf
https://www.tridonic.com/com/en/download/technical/DALI_XC_At_a_Glance_en.pdf
https://www.tridonic.com/com/en/download/technical/DALI_XC_in_MC_mode_At_a_Glance_en.pdf

- _ Documentation DALI TOUCHPANEL 02:
http://www.tridonic.com/com/en/download/Manual_x_e_touchPANEL_02_en.pdf

- _ Documentation DALI x/e-touchPANEL 02:
http://www.tridonic.com/com/en/download/technical/Manual_x_e_touchPANEL_02_en.pdf

- _ Certificates:
<http://www.tridonic.com/com/en/company-certificates.asp>

7.5.2. Downloads

- _ Tridonic software:
<http://www.tridonic.com/com/en/software.asp>

- _ Download masterCONFIGURATOR:
<http://www.tridonic.com/com/de/software-masterconfigurator.asp>

Reference list

7.5.3. Additional information

- _ Guarantee conditions:
<http://www.tridonic.com/com/en/guarantee.asp>

- _ Data sheets:
<http://www.tridonic.com/com/en/data-sheets.asp>

- _ Environmental declarations:
<http://www.tridonic.com/com/en/environmental-declarations.asp>

- _ Other technical documents:
<http://www.tridonic.com/com/en/technical-docs.asp>